

INTERNATIONAL ICE HOCKEY FEDERATION



OFFICIAL RULE BOOK 2010 – 2014

ENGLISH VERSION

July 2010

© International Ice Hockey Federation

No part of this publication may be reproduced in the English language or translated and reproduced in any other language or transmitted in any form or by any means electronically or mechanically including photocopying, recording, or any information storage and retrieval system, without the prior permission in writing from the International Ice Hockey Federation.

SECTION 1 - ICE RINK

100	DEFINITION	9
101	DIMENSIONS OF THE RINK	9
102	BOARDS	9
103	KICK PLATE	9
104	DOORS	9
105	PROTECTIVE GLASS	11
106	END ZONE NET	11
110	DIVISION AND MARKING OF THE ICE SURFACE	11
111	GOAL LINES	11
112	BLUE LINES	11
113	CENTER LINE	11
114	FACE-OFF SPOTS AND CIRCLES	13
115	CENTER FACE-OFF SPOT AND CIRCLE	13
116	FACE-OFF SPOTS IN NEUTRAL ZONE	13
117	END ZONE FACE-OFF SPOTS AND CIRCLES	13
118	REFEREE CREASE	15
119	GOAL CREASE	15
130	GOAL FRAME, POSTS AND NETTING (GOAL NET)	17
140	PLAYERS' BENCHES	17
141	PENALTY BENCHES	17
142	GOAL JUDGES' BENCHES	17
143	SCOREKEEPER BENCH	17
150	SIGNAL AND TIMING DEVICES	19
151	SIREN	19
152	CLOCK	19
153	RED AND GREEN LIGHTS	19
160	PLAYERS' DRESSING ROOMS	19
161	REFEREES' AND LINESMEN DRESSING ROOMS	19
170	RINK LIGHTING	19
171	SMOKING IN THE ARENA	19
172	MUSIC IN THE ARENA	19

SECTION 2 - TEAMS, PLAYERS AND EQUIPMENT

200	PLAYERS IN UNIFORMS	21
201	CAPTAIN OF TEAM	21
210	EQUIPMENT	21
220	PLAYER'S EQUIPMENT	21
221	PLAYERS' SKATES	21
222	PLAYER'S STICK	21
223	PLAYER'S HELMET	23
224	PLAYER'S FACE MASK AND VISOR	23
225	PLAYERS' GLOVES	23
226	NECK AND THROAT PROTECTOR	23
227	MOUTH GUARD	25
228	ELBOW PADS	25
230	GOALKEEPER EQUIPMENT	25
231	GOALKEEPER SKATES	25
232	GOALKEEPER STICKS	25
233	GOALKEEPER GLOVES	25
233a)	BLOCKING GLOVE	25
233b)	CATCHING GLOVE	27
234	GOALKEEPER HELMET AND FULL FACE MASK	27
235	GOALKEEPER LEG GUARDS	27
240	UNIFORMS	27
250	PUCK	29
260	MEASUREMENT OF EQUIPMENT	29

SECTION 3 - OFFICIALS AND THEIR DUTIES

300	APPOINTMENT OF OFFICIALS	31
310	GAME OFFICIALS	31
311	REFEREE AND LINESMEN EQUIPMENT	31
312	REFEREE DUTIES	31
313	LINESMEN DUTIES.....	31
320	OFF-ICE OFFICIALS.....	33
321	GOAL JUDGES	33
322	SCOREKEEPER.....	33
323	TIMEKEEPER.....	33
324	ANNOUNCER	33
325	PENALTY BENCH ATTENDANTS.....	33
330	VIDEO GOAL JUDGE.....	33
340	PROPER AUTHORITIES	33

SECTION 4 - PLAYING RULES

400	PLAYERS ON THE ICE	35
402	START OF GAME AND PERIODS.....	35
411	CHANGE OF PLAYERS FROM THE PLAYERS BENCH DURING PLAY	35
412	CHANGE OF PLAYERS AND GOALKEEPERS PROCEDURE DURING STOPPAGE OF PLAY	37
413	CHANGE OF PLAYERS FROM THE PENALTY BENCH.....	39
415	CHANGE OF GOALKEEPERS DURING STOPPAGE OF PLAY.....	39
416	INJURED PLAYERS	39
417	INJURED GOALKEEPERS.....	39
419	ICE CLEANING	39
420	TIMING OF GAME.....	41
421	OVERTIME PERIOD	41
422	TIME OUT.....	41
430	DETERMINING THE OUTCOME OF THE GAME.....	41
440	FACE-OFFS	43
442	PROCEDURE FOR CONDUCTING FACE-OFFS	45
450	OFFSIDES	45
451	DELAYED OFFSIDE PROCEDURE.....	47
460	ICING THE PUCK.....	47

470	DEFINITION OF A GOAL.....	49
471	DISALLOWING A GOAL.....	49
472	GOALS AND ASSIST AWARDED TO THE PLAYERS	51
480	PUCK OUT OF BOUNDS	51
481	PUCK ON THE NET.....	51
482	PUCK OUT OF SIGHT	51
483	ILLEGAL PUCK.....	53
484	PUCK STRIKING AN OFFICIAL	53
490	STOPPING/PASSING THE PUCK WITH THE HANDS	53
492	HIGH STICKING THE PUCK.....	53
493	INTERFERENCE BY SPECTATORS	55

SECTION 5 - PENALTIES

500	PENALTIES (DEFINITION AND PROCEDURES)	57
501	MINOR PENALTY	57
502	BENCH MINOR PENALTY	59
503	MAJOR PENALTY.....	59
504	MISCONDUCT PENALTY.....	59
505	GAME MISCONDUCT PENALTY	59
507	MATCH PENALTY	59
508	PENALTY SHOT.....	61
509	PENALTY SHOT PROCEDURE	61
510	SUPPLEMENTARY DISCIPLINE	63
511	GOALKEEPER PENALTY PROCEDURE.....	63
512	COINCIDENTAL PENALTIES	63
513	DELAYED PENALTY.....	65
514	CALLING OF PENALTIES	65
	FOULS AGAINST PLAYERS	67
520	BOARDING	67
521	BUTT-ENDING	67
522	CHARGING	67
523	CHECKING FROM BEHIND	69
524	CLIPPING.....	69
525	CROSS-CHECKING.....	69
526	ELBOWING	71
527	EXCESSIVE ROUGHNESS	71
528	FISTICUFFS OR ROUGHING	71
529	HEAD-BUTTING	73
530	HIGH STICKING	75
531	HOLDING AN OPPONENT	75
532	HOLDING THE STICK	75
533	HOKING.....	75
534	INTERFERENCE.....	77
535	KICKING	79

536	KNEEING	79	
537	SLASHING.....	79	
538	SPEARING.....	81	
539	TRIPPING.....	81	
540	CHECKING TO THE HEAD AND NECK AREA	83	
541	WOMEN BODY CHECKING	83	
OTHER PENALTIES			85
550	ABUSE OF OFFICIALS/UNSPORTSMANLIKE CONDUCT BY PLAYERS	85	
551	ABUSE OF OFFICIALS /UNSPORTSMANLIKE CONDUCT BY TEAM OFFICIALS	87	
554	DELAYING THE GAME	89	
554a)	KEEPING THE PUCK IN MOTION	89	
554b)	DISPLACING THE GOAL.....	89	
554c)	SHOOTING/THROWING THE PUCK OUTSIDE THE PLAYING AREA	91	
554d)	ADJUSTMENT OF EQUIPMENT.....	91	
554e)	INJURED PLAYER REFUSING TO LEAVE THE ICE.....	91	
554f)	MORE THAN ONE CHANGE AFTER GOAL SCORED	91	
554g)	VIOLATION OF FACE-OFF PROCEDURES	93	
554h)	LATE LINE-UP	93	
555	ILLEGAL AND DANGEROUS EQUIPMENT.....	93	
556	BROKEN STICK.....	95	
557	FALLING ON THE PUCK BY A PLAYER.....	95	
558	FALLING ON THE PUCK BY A GOALKEEPER.....	97	
559	HANDLING THE PUCK WITH HANDS BY A PLAYER.....	97	
560	HANDLING THE PUCK WITH HANDS BY A GOALKEEPER	99	
561	INTERFERENCE WITH SPECTATORS.....	99	
562	PLAYERS LEAVING THE PLAYER’S BENCH OR PENALTY BENCH.....	99	
565	TEAM OFFICIALS LEAVING THE PLAYER’S BENCH	101	
566	REFUSING TO START PLAY TEAM ON THE ICE	101	
567	REFUSING TO START PLAY TEAM NOT ON THE ICE.....	101	
568	THROWING A STICK OR ANY OBJECT OUT OF THE PLAYING AREA... ..	101	
569	THROWING A STICK OR ANY OBJECT WITHIN THE PLAYING AREA... ..	103	
570	THROWING A STICK OR ANY OBJECT ON A BREAKAWAY SITUATION ..	103	
571	PREVENTION OF INFECTIONS BY BLOOD.....	103	
572	CAPTAIN, ALTERNATE CAPTAIN COMPLAINT	105	
573	TOO MANY PLAYERS ON THE ICE	105	
575	INFRINGEMENT OF CHANGE OF PLAYERS PROCEDURE	105	
576	DIVING	105	
590 PENALTIES FOR GOALKEEPERS.....			105
591	GOALKEEPER BEYOND THE CENTER RED LINE	107	
592	GOALKEEPER GOING TO THE PLAYER’S BENCH	107	
593	GOALKEEPER LEAVING THE GOAL CREASE DURING AN ALTERCATION	107	
594	GOALKEEPER DROPPING THE PUCK ON THE GOAL NETTING.....	107	
595	PROTECTION OF GOALKEEPERS	107	

ANNEX 1 ADVERTISING REGULATIONS.....		109
ANNEX 2 COUNT-DOWN AND WARM-UP PROCEDURES.....		109
ANNEX 3 OFFICIAL ANNOUNCEMENTS		111
A3.1	COMPULSORY ANNOUNCEMENTS.....	111
A3.2	PUBLIC INFORMATION	111
ANNEX 4 DUTIES OF THE OFFICIALS		112
A4.1	INCAPACITATED REFEREE OR LINESMAN BEFORE THE GAME	112
A4.2	INCAPACITATED REFEREE OR LINESMAN DURING THE GAME.....	112
A4.3	THREE MAN SYSTEM	112
A4.4	REFEREE DUTIES BEFORE THE GAME	112
A4.5	REFEREE DUTIES DURING THE GAME	112
A4.6	REFEREE DUTIES AFTER THE GAME	113
A4.7	LINESMEN DUTIES.....	113
A4.8	TWO MAN SYSTEM.....	114
A4.9	REFEREE DUTIES BEFORE THE GAME.....	114
A4.10	REFEREE DUTIES DURING THE GAME	114
A4.11	REFEREE DUTIES AFTER THE GAME	114
A4.20	OFF-ICE OFFICIALS.....	115
A4.21	SCOREKEEPER DUTIES BEFORE THE GAME.....	115
A4.22	SCOREKEEPER DUTIES DURING THE GAME	115
A4.23	SCOREKEEPER DUTIES AFTER THE GAME	116
A4.24	TIMEKEEPER DUTIES	116
A4.25	ANNOUNCER DUTIES	116
A4.26	PENALTY BENCH ATTENDANTS DUTIES	116
ANNEX 5 ILLUSTRATION OF GOAL FRAME		117
ANNEX 5 REFEREES AND LINESMEN SIGNALS.....		117
INDEX		126

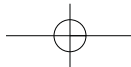

ICE RINK

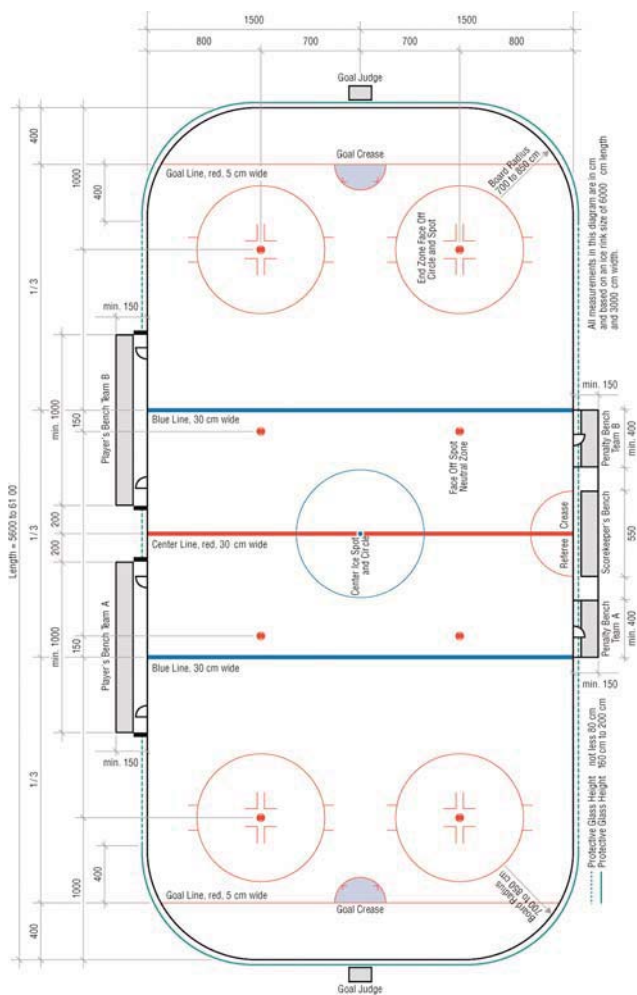

SECTION 1 - ICE RINK

There shall be **no markings** on the ice, boards, protective glass, nets, goals, or on any surface in and around the players benches, penalty benches, goal judge benches or off-ice officials areas, except as specified under these rules or as provided in Annex 1 (Advertising regulations)

100 - DEFINITION OF THE RINK

The game of ice hockey shall be played on a white ice surface known as a "Rink".

101 - DIMENSIONS OF THE RINK

Maximum size: **61 metres long by 30 metres wide.**

Minimum size: **56 metres long by 26 metres wide.**

The corners shall be rounded in the arc of a circle with a radius of **7 to 8.5 metres.**

► For IIHF competitions the size will be **60 to 61 metres long by 29 to 30 metres wide.**

102 - BOARDS

- The rink shall be surrounded by a wooden or plastic wall known as the "Boards" which shall be white in colour.
- They shall be not less than **1.17 metres** and not more than **1.22 metres in height** above the level of the ice surface.
- The boards shall be constructed in such a manner that the surface facing the ice shall be smooth and free of any obstruction that could cause injury to the players and the protective screens and gear used to hold the boards in position shall be mounted on the side away from the playing surface.
- The gaps between the panels shall be minimized to 3mm.

103 - KICK PLATE

At the lower part of the boards shall be fixed a "Kick Plate", yellow in colour, **15 to 25 cm in height** above the ice surface level.

104 - DOORS

- All doors giving access to the ice surface must **swing away from the ice surface.**
- The gaps between the door and the board shall be minimized to 5 mm.



► For IIHF competitions, the protective glass and end zone nets are obligatory.

PROTECTIVE GLASS AND BOARDS
All measurements in cm.

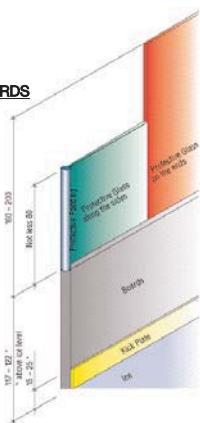

- 1. On open air rinks, all of the lines and face-off spots outlined in Rules 112 and 113 shall be marked by two lines 5 cm wide.
- 2. In case of advertising allowed on the boards, the lines shall be at least be marked on the kick plate.
- 3. The entire width of the line shall be considered as part of the zone that the puck is in.

DIVISION OF ICE SURFACE

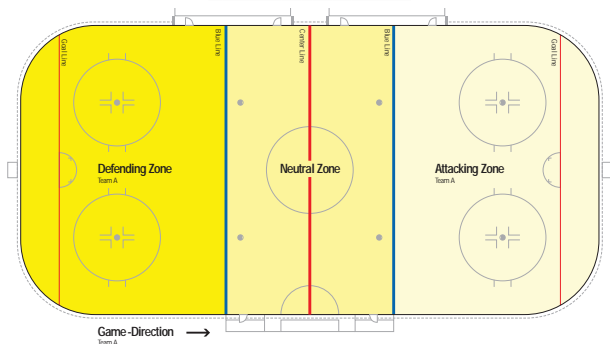

105 - PROTECTIVE GLASS

- a) The protective glass located above the boards shall be **160 cm to 200 cm in height** on the ends and shall extend 4 metres from the goal line towards the neutral zone and **not less than 80 cm in height** along the sides, except in front of the player benches.
- b) The gaps between the glass panels shall be minimized to 5 mm.
- c) At any interruption of the protective glass there shall be protective padding to prevent the injury of the players.
- d) No openings are allowed in the protective glass

106 - END ZONE NETS

Protective nets must be suspended above the end zone boards and glass.

110 - DIVISION AND MARKING OF THE ICE SURFACE

The ice surface shall be divided in its length by **five lines** marked on the ice and extending completely across the ice surface and continuing vertically up the boards.

111 - GOAL LINES

Lines shall be marked **4 metres** from each end of the ice rink, **5 cm wide** and **red** in colour, known as the **"Goal Lines"**

112 - BLUE LINES

- a) The ice area between the two goal lines shall be divided in three equal parts by lines 30 cm wide and blue in colour known as the **"Blue Lines"**. The Blue Lines shall extend **NEW** up the Kick Plate and onto the boards
- b) These lines shall determine the **three Zones**, defined as follows:

For one team, the zone in which their goal is situated is the: **"Defending Zone"**
 The central zone is the: **"Neutral Zone"**
 The farthest zone is the: **"Attacking Zone"**

113 - CENTER LINE

A line known as the **"Center Line"** shall be located in the middle of the rink. It shall be **30 cm wide** and red in colour.



CENTER ICE SPOT AND CIRCLE

All measurements in cm

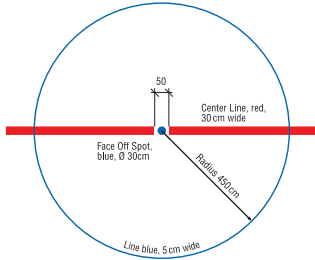

114 - FACE-OFF SPOTS AND CIRCLES

All spots and circles are marked on the ice surface in order to position the players for a face-off as ordered by the officials at the beginning of the game, at the beginning of each period and after each stoppage of play.

END ZONE FACE-OFF CIRCLE AND SPOT

All measurements in cm

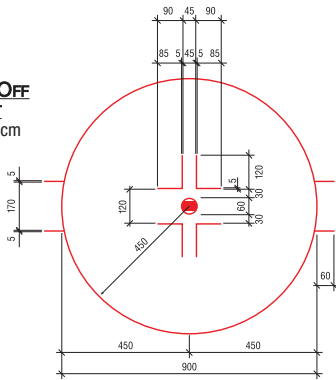

115 - CENTER FACE-OFF SPOT AND CIRCLE

A circular blue spot, **30 cm in diameter**, shall be marked exactly in the center of the rink.

With this spot as a center, a circle with a **radius of 4.5 metres** shall be marked with a blue line **5 cm wide**.

116 - FACE-OFF SPOTS IN NEUTRAL ZONE

Two red spots, **60 cm in diameter**, shall be marked in the neutral zone, **1.5 metres** from each blue line as illustrated on the opposite page.

DETAIL OF FACE-OFF SPOT

All measurements in cm

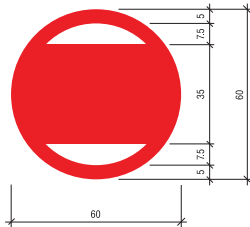

117 - END ZONE FACE-OFF SPOTS AND CIRCLES

- a) Face-off spots and circles shall be marked on the ice in both end zones and on both sides of each goal as illustrated on the opposite page.
- b) The face-off spots shall be **60 cm** in diameter, red in colour, as illustrated on the opposite page.
- c) On opposite sides of the end zone face-off spots shall be marked **double "L"**, as illustrated on the opposite page.
- d) The circles shall have a **radius of 4.5 metres** from the center of the face-off spots and marked with a red line, **5 cm wide**.

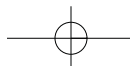

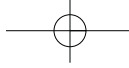

REFEREE CREASE
All measurements in cm

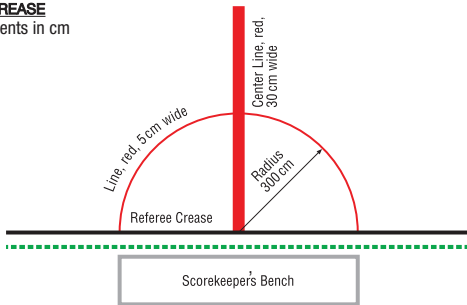

118 - REFEREE CREASE

An area known as the "Referee Crease" shall be marked on the ice in a semi-circle by a red line, 5 cm wide, and with a radius of 3 metres, immediately in front of the Scorekeepers Bench, as illustrated on the opposite page.

GOAL CREASE
All measurements in cm

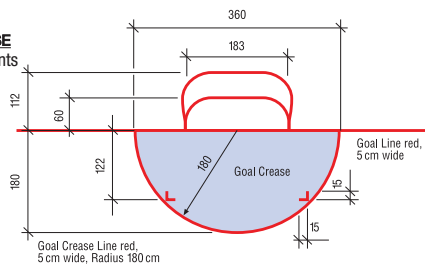

119 - GOAL CREASE

- In front of each goal a "Goal Crease" area shall be marked by a red line, 5 cm wide, as illustrated on the opposite page.
- The goal crease area shall be painted light blue. The inside of the goal area from the goal line to the back of the net shall be white.
- The goal crease shall include all the space outlined by and include the crease line and extending vertically 1.27 metres to the top of the goal frame.
- The goal crease shall be laid out as follows:
 - A semi-circle 180cm in radius and 5cm in width shall be drawn using the center of the goal as the center point.
 - In addition, an "L" shaped marking of 15cm in length (both lines) at each front corner shall be painted on the ice
 - The location of the "L" marking is measured by drawing an imaginary line 122cm from the goal line to the edge of the semi-circle. At the point the "L" shall be drawn.

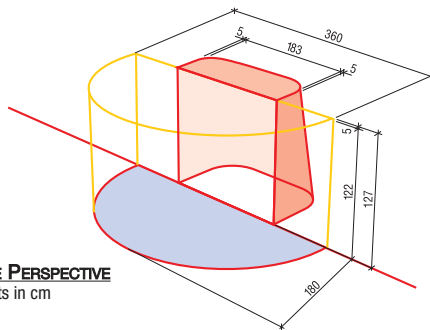

GOAL CREASE PERSPECTIVE
All measurements in cm

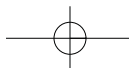

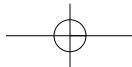

▶ 1. Goal posts and nets shall be set in such manner as to remain stationary during the progress of the game.

NEW

▶ 2. For the Olympic Winter Games tournaments, the IIHF World Championship, the IIHF World Women Championship, the IIHF World Championship Division I, the IIHF World Under 20 Championship and the IIHF World U18 Championship, **flexible goal pegs** are mandatory and are strongly recommended for other IIHF competitions.



- ▶ 1. Each player's bench must have two doors, one of which must be in the **NEUTRAL ZONE**.
- ▶ 2. The player benches must be protected from access by persons other than the players and the team officials.
 - ▶ **Report** to the Proper Authorities if not so.

PLAYERS' BENCHES AND PENALTY BENCHES
All measurements in cm

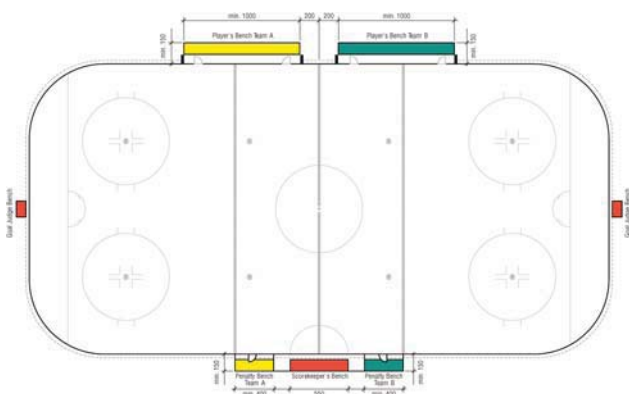

130 - GOALS

- a) The goals shall be located in the center of the goal lines.
- b) The goal posts shall extend vertically **1.22 metres** above the ice surface and be **1.83 metres** apart (internal measurements). The goal posts and horizontal crossbar that form the tubular steel frame shall be of a specified design with an external diameter of **5 cm** and shall be painted red.
- c) The goal posts and horizontal crossbar shall be completed by a frame supporting the netting, the deepest point of which shall not be more than **1.12 metres** or less than **0.60 metres**. It shall be painted white.
- d) A netting of white nylon cord shall be draped over to enclose the back of the goal frame in such a manner as to prevent the puck from coming to rest on the outside of it, yet strung in a manner that shall keep the puck inside the goal net.
- e) The inside parts of the supports, other than the goal posts and the crossbar, shall be covered by white padding. The padding of the base frame shall start not less than 10 cm's from the goal post and shall be attached in a manner that shall not restrict the puck from completely crossing the goal line.

140 - PLAYERS' BENCHES

- a) Each rink shall be provided with two identical benches, exclusively for the use of players in uniform and officials of both teams.
- b) The benches shall be on the same side of the rink, immediately along the ice but opposite to the penalty benches, separated by a substantial distance or by other facilities, and convenient to the dressing rooms.
- c) Each bench shall begin **2 metres** from the center line with a minimum length of **10 metres** and a minimum width of **1.50 metres**.
- d) Each bench shall accommodate: **16 players and 8 team officials**.

NEW

141 - PENALTY BENCHES

- a) Each rink shall be provided with two benches to be known as the penalty benches for a minimum of **5 players each**.
- b) They shall be located on both sides of the Scorekeepers desk and opposite to the player's benches and shall have minimum length of **4 metres** and a minimum width of **1.50 metres**.
 - ▶ Access to the penalty benches shall be restricted to persons other than the penalized players and the Penalty Bench attendants.

142 - GOAL JUDGES' BENCHES

Properly protected cages to eliminate interference with the Goal Judge's activities shall be placed at each end of the rink behind the board and glass in the area of the goal.

143 - SCOREKEEPER BENCH

Between the penalty benches shall be located the Scorekeeper Bench which shall have a length of **5.5 metres** to accommodate **6 people**.

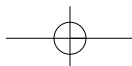

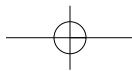

- ▶ Electronic scoreboards with videotext are recommended for IIHF competitions.
- ▶ 1. The red light shall be connected to the timing device in such a manner so that, when the period has ended, it would be impossible for the Goal Judge to turn it on.
- ▶ 2. At the end of a period, the fact that the Goal Judge is not able to turn on the red light does not necessary mean that a goal is not valid. The determining factor is whether or not the puck is completely over the goal line and in the goal before the period ends.
- ▶ 3. The purpose of the green light is to enable the Referee and Linesmen to observe the goal and light in the same sight line and know exactly when the period ends.
- ▶ No one, except as authorised by the association concerned, shall be allowed to enter the Officials dressing room during the course of or immediately following the game. In case of an infraction to this rule report to the proper authorities.
- ▶ 1. If, in the opinion of the Referee, there is not sufficient light to continue the game, he shall have the authority to postpone the remainder of the game or a take time-out, pending improvement of the lighting situation.
- ▶ 2. If one team is handicapped to a greater extent by the failure of lights, and in the opinion of the Referee the game should not be cancelled, he shall have the authority to alternate the teams so that each team will play the same amount of time in each end of the rink.



- ▶ Music may be played during the warm-up and during any stoppage of play.

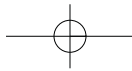

150 - SIGNAL AND TIMING DEVICES

151 - SIREN

Each rink shall be provided with a siren or other suitable sound device to be used by the Timekeeper.

152 - CLOCK

Each rink shall have an electric clock (scoreboard) in order to provide spectators, players and officials with accurately information concerning:

1. **Names of both teams**
2. **Time played in any period**, counting down in minutes and seconds from 20:00 to 0:00, **NEW**
3. **Penalty time remaining** to be served for at least two players on each team counting down from the total number of penalty minutes to 00:00.
4. **Score**
5. **Team time-outs**, counting down from 00:30 to 00:00 seconds.
6. **Intermission time**, counting down from 15:00 to 00:00 minutes.

153 - RED AND GREEN LIGHTS

Behind each goal there shall be:

1. A red light to be lit by the Goal Judge when a goal is scored,
2. A green light to be lit automatically by the electric clock when the Timekeeper **NEW** stops the clock at a stoppage of play and at the end of each period.

160 - PLAYERS' DRESSING ROOMS

Each team shall be provided with a suitable room with sufficient space for **30 team officials and players** and their equipment, equipped with benches, sanitary toilet and showers.

161 - REFEREE'S AND LINESMEN DRESSING ROOM

A separate dressing room equipped with chairs or benches, sanitary toilet and shower must be provided for the exclusive use of the Referees and Linesmen.

170 - RINK LIGHTING

All rinks shall be sufficiently well illuminated so that the players, officials and spectators may conveniently follow the play at all times.

171 - SMOKING IN THE ARENA

In enclosed rinks, smoking shall be prohibited in the playing and spectator areas, as well as in the dressing rooms and all the facilities where the players are involved.

172 - MUSIC IN THE ARENA

- a) **No music** shall be played while the game is in progress, or during the team time-outs. **NEW**
- b) Compressed air horns and whistles are forbidden in the ice rink.
- c) No music shall be played if and when an injured player lays on the ice at a stoppage **NEW**

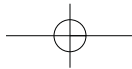

- ▶ 1. **No changes** or additions shall be permitted to the list once the game has started.
- ▶ 2. If, during the game, a team cannot place the correct number of players on the ice because of penalties or injuries, the Referee shall declare the game a **forfeit** and:
 - ▶ **Report** to the Proper Authorities.

- ▶ 1. It is not permitted to appoint a goalkeeper, Playing Coach or Manager as a Captain or Alternate Captain.
- ▶ 2. If a Captain or Alternate Captain is not on the ice, they cannot come off the bench to discuss any situation with the Referee, unless invited by the Referee. If the captain does come off the player's bench uninvited, he shall be sent back and the coach warned that a second violation shall result in a
 - ▶ **Misconduct** penalty (see Rule 572)
- ▶ 3. If both the Captain and Alternate Captain are on the ice, only the Captain has the privilege of conversing with the Referee.
- ▶ 4. Players that do not wear a "C" or "A" on their jersey shall not be granted the privileges of conversing with the Referee.



- ▶ 1. The official playing rules specify the use of protective equipment out of concern for the orderly playing of the game, and for the safety, health and welfare of participants. However, such rules do not imply a guarantee by the IIHF that the use of such equipment will provide protection from injury. It is the responsibility of the player to ensure that the equipment used conforms, where specified, with the official playing rules and is worn and maintained in good condition in accordance with the manufacturer's warranties.
- ▶ 2. For advertising and/or brand identification on the player's equipment, see Annex 1.



PLAYER SKATE



SECTION 2 - TEAMS, PLAYERS AND EQUIPMENT

200 - PLAYERS IN UNIFORM

- a) Before the game, the Manager or Coach of each team shall provide the Referee or Scorekeeper with a list of names and numbers of eligible players and goalkeepers, including the names of the Captain and Alternate Captains.
- b) Each team shall be allowed a maximum of:
 - **20 players**, and
 - **2 goalkeepers**,
 - for a total of **22**.

201 - CAPTAIN OF TEAM

- a) Each team shall appoint a "**Captain**" and no more than two "**Alternate Captains**".
- b) The Captain shall wear the letter "C" and Alternate Captains shall wear the letter "A", **8 cm in height** and in a contrasting colour, in a conspicuous position on the front of their sweater.
- c) On the ice, only these designated players, if they are not penalized, shall have the privilege to discuss with the Referee any questions relating to the interpretation of rules that may arise during the course of the game.
- d) A complaint concerning a penalty is NOT a matter relating to the interpretation of the rules and shall be penalized with a Misconduct penalty (see Rule 572)

210 - EQUIPMENT

- a) Players and goalkeeper's equipment shall consist of sticks, skates, protective equipment and uniforms.
- b) All protective equipment, except gloves, helmets and goalkeepers leg guards, must be worn entirely underneath the uniform.
- c) All infractions related to the wearing of equipment shall be penalized under Rule 555.
- d) Complete equipment including jerseys must be worn during the pre-game warm-up. **NEW**

220 - PLAYER'S EQUIPMENT

221- PLAYER'S SKATES

The players shall wear "**Ice Hockey Skates**" with safety blades.

222 - PLAYER'S STICK

- a) Sticks shall be made of wood or other material approved by the IIHF.
- b) It shall not have any projections and all edges shall be bevelled.
- c) The top end of a hollow shaft stick must have a form of protection **NEW**
- d) Adhesive non-fluorescent tape of any color may be wrapped around the stick at any place. **NEW**
- e) Fluorescent painted sticks are not permitted and shall be removed. If a player refuses to remove the stick, access a misconduct penalty under Rule 555.

- ▶ The players stick blade may be **curved**, and the curvature shall be restricted in such a way that the distance of a perpendicular line, measured from a straight line drawn from any point at the heel to the end of the blade, shall not exceed **1.5 cm**.

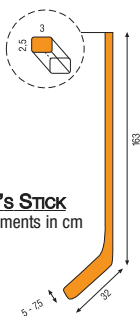

PLAYER'S STICK
All measurements in cm

PLAYER'S HELMET



PLAYER'S VISOR



FULL FACE MASKS



- ▶ Rule 224 applies for male players; **NEW**

Born in 1993 - for season 2010/2011
 Born in 1994 - for season 2011/2012
 Born in 1995 - for season 2012/2013
 Born in 1996 - for season 2013/2014

- ▶ Each national association participating in an IIHF Championship shall ensure that each of their players is equipped with a hockey helmet and where applicable, a visor or face mask, properly attached to the helmet all fit for the purpose for which they were intended by the manufacture
- ▶ The full face masks shall be constructed in such a way that neither the puck nor a stick blade might get through it

- ▶ Rule 226 applies for male and female players; **NEW**

Born in 1993 - for season 2010/2011
 Born in 1994 - for season 2011/2012
 Born in 1995 - for season 2012/2013
 Born in 1996 - for season 2013/2014

f) Player's Stick Dimensions:

- 1. Shaft:** maximum length - **163 cm** from the heel to the end of the shaft
 maximum width - **3 cm**
 maximum thickness - **2.5 cm**
 The shaft must be straight
- 2. Blade:** maximum length - **32 cm** from the heel to the end of the blade
 maximum width - **7.5 cm**
 minimum width - **5 cm**

223 - PLAYER'S HELMET

- During the game and during the pre-game warm-up, all players shall wear a hockey helmet with chin strap properly fastened.
- Where a player(s) fails to wear a helmet during the pre-game warm-up in International competitions, the stand by Referee shall report to the Chairman who shall report to the Directorate or the IIHF Disciplinary Committee. In National competitions, the procedure shall follow the National association rules in this matter.
- A helmet shall be worn so that the lower edge of the helmet is not more than one finger-width above the eyebrows, and there should only be enough room between the strap and the chin to insert one finger.
- Should the helmet of a player come off while play is in progress, the player shall not be permitted to participate in the play and must go directly to the player's bench. **NEW**
- If the player continues to play without his helmet he shall be penalized under Rule 555 g).

224 - PLAYER'S FACE MASK AND VISOR

- It is recommended that all players shall wear a full-facemask or a visor.
- Male players born after **December 31, 1974** shall wear, as a minimum, a visor.
- The visor shall extend down to cover the eyes and the lower edge of the nose in frontal and lateral projections.
- All female players shall wear full-face masks.
- All players and goalkeepers in the category under 18 years and younger shall wear a full-face mask
- Players shall not be permitted to wear coloured or tinted visor or tinted full-face mask.

225 - PLAYERS' GLOVES

The player's gloves shall cover hand and wrist and their palm shall not be removed to permit the use of bare hands.

226 - NECK AND THROAT PROTECTOR

- It is recommended that all players wear a neck and throat protector.
- All players and goalkeepers in the category under 18 years and younger must wear a neck and throat protector.

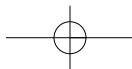

► Rule 227 applies for male players; **NEW**

Born in 1991 - for season 2010/2011
 Born in 1992 - for season 2011/2012
 Born in 1993 - for season 2012/2013
 Born in 1994 - for season 2013/2014

GOALKEEPER'S STICK
 All measurements in cm

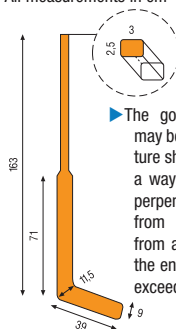

► The goalkeeper's stick blade may be **curved**, and the curvature shall be restricted in such a way that the distance of a perpendicular line, measured from a straight line drawn from any point at the heel to the end of the blade, shall not exceed **1.5 cm**.

BLOCKER GLOVE

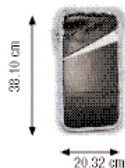

GOALKEEPER FULL FACE MASK

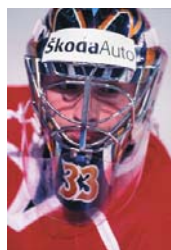

GOALKEEPER'S SKATE



227 - MOUTH GUARD

- a) It is recommended that all players wear a custom-made mouth guard.
- b) All players in the age category under 20 must wear a mouth guard.

NEW

228 - ELBOW PADS

All elbow pads which do not have a soft protective outer covering of sponge rubber or similar material of at least 1.27 cm thickness shall be considered as dangerous equipment

NEW

230 - GOALKEEPER'S EQUIPMENT

- a) With the exception of skates and stick, all the equipment worn by the goalkeeper shall be constructed solely for the purpose of protecting the head and the body and shall not include any garment or addition which would give the goalkeeper undue assistance in keeping goal.
- b) Abdominal aprons, extending down the front of the thighs on the outside of the pants, are prohibited.

231 - GOALKEEPERS' SKATES

The goalkeeper shall wear special **"Goalkeeper Skates"** of approved design.

232 - GOALKEEPERS' STICKS

- a) Sticks shall be made of wood or other material approved by the IIHF.
- b) It shall not have any projections and all edges shall be bevelled.
- c) The top end of the shaft must have a form of protection
- d) Adhesive non-fluorescent tape of any colour may be wrapped around the stick at any place.
- e) Fluorescent painted sticks are not permitted and shall be removed. If a goalkeeper refuses to remove the stick, access a misconduct penalty under Rule 555.
- f) Dimensions:
 - 1. **Shaft:** maximum length - **163 cm** from the heel
 maximum width - **3 cm**
 maximum thickness - **2.5 cm**
Widened part of the shaft: maximum length - **71 cm** from the heel and not more than **9 cm** wide. The shaft and shank shall be straight.
 - 2. **Blade:** maximum length - **39 cm** from the heel
 maximum width - **9 cm**, except at the heel where it shall not exceed **11.5 cm**

NEW

NEW

233 - GOALKEEPERS' GLOVES

233a) - BLOCKING GLOVE

The maximum outside dimensions of the protective padding attached to the back, forming part of a blocking glove, shall not exceed:

- **38.1 cm** in length
- **20.32 cm** in width

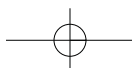

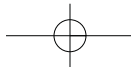

CATCHING GLOVE

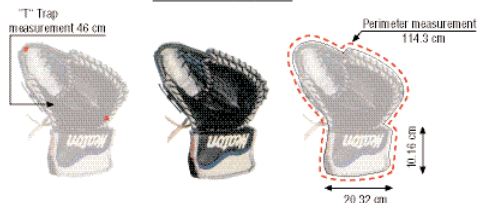

HELMET OFF GOALKEEPER

LEG GUARDS

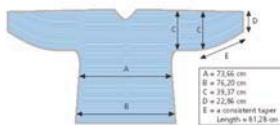
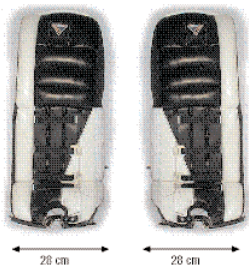

GOALKEEPER JERSEY MEASUREMENTS

A = 71.56 cm
B = 36.20 cm
C = 39.37 cm
D = 22.86 cm
E = a consultant tagger
Length = 61.28 cm

- ▶ 1. Any player that does not comply with these provisions **shall not be permitted to participate** in the game.
- ▶ 2. If, in the opinion of the Referee, the uniform colours of the competing teams are so similar that there is the possibility of miscalling a penalty, it is the responsibility of the **home team** to change their sweaters, if ordered to do so by the Referee.
- ▶ 3. If a player's hair is long and obscures the name plate or number on the sweater, the hair shall be worn in a pony tail or under the helmet.
- NEW** ▶ 4. Graffiti type of designs, patterns or art work **shall not be permitted** on goalkeepers' pads or gloves.
- NEW** ▶ 5. Any drawings or slogans which are abusive or obscene and/or refer to cultural, racial and religion **shall not be permitted** on any type of equipment including the helmet and facemask.

233b) - CATCHING GLOVE

- a) The maximum outside dimensions of the catching glove shall not exceed:
 - ▶ **20.32 cm** in length in any part of the wrist cuff, which shall be **10.16 cm** in width (height)
 - ▶ Distance from the heel along the pocket to the top of the T trap shall be no more than **46 cm**.
- b) The perimeter of the catching glove shall not exceed **114.3 cm**.

234 - GOALKEEPER'S HELMET AND FACE MASK

- a) All goalkeepers shall wear a hockey helmet with a facemask or hockey goalkeepers head protector with a facemask. The goalkeepers facemask shall be constructed in such a way that a puck shall not get through it. **NEW**
- b) The facemask of goalkeepers in the category under 18 years of age in male and female hockey shall be constructed in such a way that neither a puck nor a stick blade can enter through the openings. **NEW**
- c) Should the helmet and facemask or the head protector and facemask come off while play is in progress, the Referee shall stop play. **NEW**
- d) Should a hard shot hit the goalkeeper's facemask, while play is in progress, the play may be stopped at the discretion of the Referee only if no immediate scoring chance is presented to the opposing team. **NEW**
- e) If a goalkeeper removes his helmet and/or facemask in order to bring a stoppage in play, the Referee shall assess the offending goalkeeper a minor penalty. **NEW**
- f) If a goalkeeper removes his helmet and/or facemask in order to bring the stoppage in play in a break away situation, the Referee shall award to the non-offending team a Penalty Shot (PS).
- g) If a goalkeeper removes his helmet and/or facemask in order to bring the stoppage in play during a Penalty Shot, the Referee shall award to the non-offending team a goal. **NEW**

235 - GOALKEEPERS' LEG GUARDS

- a) The goalkeeper's leg guards shall not exceed **28 cm wide** when on the leg of the goalkeeper.
- b) A piece of any material covering the space between the ice and the bottom of the leg guards in front of the skates is not permitted.

240 - UNIFORMS

- a) **All players** from each team shall be dressed uniformly in sweaters, pants, stockings and helmet (except of the goalkeeper who is permitted to wear a helmet of a different colour to the rest of the team).
- b) The **basic colour** shall cover approximately **80%** of each part of the equipment, excluding names and numbers.
- c) Sweaters, including the sleeves and stockings shall be of the same colour.
- d) Sweaters shall be worn outside of the pants.
- e) Each player shall wear an individual number **25cm to 30cm high** on the back of the sweater and **10cm high** on both sleeves. Numbers are limited to the numbers **1 to 99**.

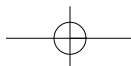

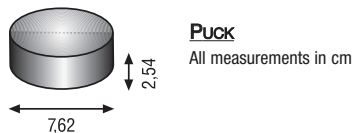

Puck Logo

NEW ▶ The printed logo, trademark and/or advertising shall not exceed in diameter 4.5 cm of the area of each side of a puck or 35% of the area of each side of the puck. There may be printing on both sides of a puck.

f) In IIHF competitions, each player shall wear his name on the upper portion of the back of his sweater, printed 10cm high, in block capital Roman letters.

250 - Puck

- a) The "Puck" shall be made of vulcanized rubber or other material approved by the IIHF and be primarily black in colour.
- b) The dimensions of a puck shall not exceed:
 - ▶ Diameter - **7.62 cm**
 - ▶ Thickness - **2.54 cm**
 - ▶ Weight - **156 to 170 gms**

260 - MEASUREMENT OF EQUIPMENT

- a) The Referee may, at any time and at his own discretion, measure any equipment.
- b) The Captain of a team may make a formal complaint against specific dimension of any equipment. The Referee shall make the necessary measurement immediately. However, no goal shall be disallowed as a result of any measurement.
- c) If the complaint is not sustained, the requesting team shall be penalized with a Bench **Minor penalty** (see Rule 555)
- d) If the complaint is sustained, the guilty player shall be penalized with a **Minor penalty** (see Rule 555)
- e) Such request shall be limited to one team at any stoppage of play.
- f) The measurement of goalkeeper's equipment, with the exception of the stick, may only be requested immediately at the end of any period.
- g) If a captain of the team that is two men short in the last two minutes of the game or in any time in overtime, requests an equipment measurement that proves to be legal equipment following the measurement, the Referee shall award to the non-offending team a **Penalty Shot** (PS).

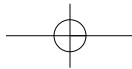

- NEW ▶** 1. Officiating systems utilised by the IIHF in an IIHF competition include the **Three-Man System** (1 referee and 2 linesmen) or the **Four-Man System** (2 referees and 2 linesmen)
- NEW ▶** 2. The duties of Referees in the Four Man System **are the same** as in the Three Man System.
- NEW ▶** 3. National Associations have the authority to use the **Two Man System** (two game officials working as both referee and linesman) in games, which are completely under their jurisdiction.

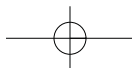

SECTION 3 - OFFICIALS AND THEIR DUTIES

300 - APPOINTMENT OF OFFICIALS

For all international games, the following officials shall be appointed:

GAME OFFICIALS

- One **Referee**
- Two **Linesmen**
- OR**
- Two **Referees**
- Two **Linesmen**

NEW

OFF-ICE OFFICIALS

- Two **Goal Judges**
- One **Scorekeeper** (with up to two assistants)
- One **Timekeeper**
- One **Announcer**
- Two **Penalty Bench Attendants**
- One **Video Goal Judge** (may be required at IIHF events)

310 - GAME OFFICIALS

311 - REFEREE AND LINESMEN EQUIPMENT

- a) All Referees and Linesmen shall be dressed in black trousers and official sweaters.
- b) All Referees and Linesmen shall wear skates and a black hockey helmet with a visor, and shall be equipped with whistle and metal tape measure with a minimum **2 metre** length.
- c) The Referee shall wear red or orange armbands, **8 to 10 cm wide**, on the upper part of each sleeve (only in the three or the four man system).

312 - REFEREE DUTIES

The Referee shall have general supervision of the game, full control of game officials and players, and his decision shall be final in case of any dispute.

313 - LINESMEN DUTIES

- a) The Linesmen shall be responsible mainly for the infractions concerning the lines (off-side, icing the puck).
- b) They shall face-off the puck in most circumstances and will assist the Referee in conducting the game.
- c) The complete duties of the Referee and Linesmen are outlined in Annex 4.



- ▶ If, after the start of the game, it becomes apparent that a Goal Judge is guilty of giving unjust decisions, the Referee shall appoint another Goal Judge.



REFEREE DISCUSSING WITH VIDEO GOAL JUDGE

320 - OFF-ICE OFFICIALS

321 - GOAL JUDGE

- a) There shall be one goal judge stationed behind each goal. The Goal Judges shall not change goals during the game. In IIHF competitions they may not be nationals of either team engaged in the game.
- b) The Goal Judge shall decide **only if the puck has passed between the goal posts and completely over the goal line**, and shall then give the appropriate signal.
- c) The **Referee** may consult with the Goal Judge, but the **Referee shall give the final decision** in matters of a disputed goal.

322 - SCOREKEEPER

The complete duties of the Scorekeeper are outlined in Annex 4.21 to 4.23.

323 - TIMEKEEPER

The complete duties of the Timekeeper are outlined in Annex 4.24

324 - ANNOUNCER

The complete duties of the Announcer are outlined in Annex 4.25.

325 - PENALTY BENCH ATTENDANT

There shall be one Penalty Bench Attendant per team penalty bench. The complete duties of the Penalty Bench Attendant are outlined in Annex 4.26

330 - VIDEO GOAL JUDGE SYSTEM

- a) Video Goal Judge System (VGJ) shall be applied only by at the request of the Referee or the Video Goal Judge.
- b) The following are the only situations subject to review by the Video Goal Judge
 1. Puck crossing the goal line.
 2. Puck in the net prior to the goal frame being displaced.
 3. Puck in the net prior to or after the expiration of time at the end of a period.
 4. Puck directed into the net by hand or kicked into the net.
 5. Puck deflected into the net off a game official.
 6. Puck struck with a high stick above the height of crossbar by an attacking player prior to entering the net.
 7. Establishing the correct time on the official clock, provided the game time is visible on the Video Goal Judge's monitor.

340 - PROPER AUTHORITIES

The term "**Proper Authorities**" or "**Proper Disciplinary Authorities**" as applied under these rules, is defined as the immediate governing body of the games involved.

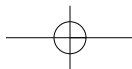

- ▶ 1. Each team shall be allowed to have only one goalkeeper on the ice at one time while play is in progress.
- ▶ 2. This goalkeeper may be removed and substituted by a player. However, such player shall not be permitted the privileges of the goalkeeper.

- ▶ 1. If the home team has not been established, the competing teams shall decide which team shall be the home team by mutual agreement, by the flip of a coin or some similar method.
- ▶ 2. **Home team privileges:**
 1. Choice of the players bench,
 2. Choice of uniform colours.
 3. At the face-off following a stoppage of play, the home team shall place its line-up on the ice after the visiting team.
- ▶ 3. At any time in the game, the Referee may request, through the Captain, that the visiting team put a playing line-up on the ice to promptly commence play.

- ▶ 1. No warm-up shall be allowed to any player or goalkeeper at the end of the first and second period, or at any stoppage of play.
- ▶ 2. Teams shall not change ends when the ice is not resurfaced for overtime or game winning shots.
- ▶ 3. In the application of the rule, the change of one or more players shall constitute a line change.

CHANGING AREA FOR PLAYERS
All measurements in cm

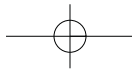
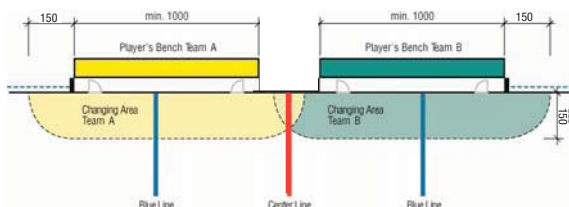

SECTION 4 - PLAYING RULES

400 - PLAYERS ON THE ICE

A team shall not have more than **six players** on the ice at any time while play is in progress.

- ▶ **Bench Minor** penalty for Too Many Players on the Ice (Rule 573).

The six players shall be:



402 - START OF GAME AND PERIODS

- a) The game shall begin at the scheduled time with a face-off at the center face-off spot. A face-off conducted in the same manner shall take place at the start of each period.
- b) The teams shall start the game defending the goal nearest to their player bench.
- c) Teams shall change ends for each succeeding regular or overtime period.

411 - CHANGE OF PLAYERS AND GOALKEEPERS FROM THE PLAYER'S BENCH DURING PLAY

NEW

- a) The players and Goalkeepers may be changed at any time from the players bench while the game is in progress provided that:
 1. The changing players and Goalkeepers are within an imaginary area limited by the length of the respective players bench and 1.5 metres from the boards, as illustrated on the opposite page.
 2. The changing players and Goalkeepers are out of the play before any change is made.
 3. A team that is in violation of icing shall not be permitted to make any player substitutions prior to the ensuing face-off. (see Rule 460)
- b) If, during a substitution, the player entering the game plays the puck or makes any physical contact with an opponent while the retiring player is actually on the ice, there shall be a Bench Minor penalty for Too Many Players on the Ice (Rule 573).
- c) If, during a substitution, the goalkeeper departing the ice plays the puck or makes any physical contact with an opponent while the entering player is actually on the ice, the Referee shall assess a Bench Minor penalty for Too Many Players on the Ice (rule 573)
- d) If during the substitution, either the entering player or retiring player is struck accidentally by the puck, the play shall not be stopped and no penalty called.
- e) If a goalkeeper leaves his crease and proceeds to his player's bench for the purpose of substituting another player and if the substitution is made prematurely, the Referee shall stop the play when the offending team gains possession of the puck. The ensuing face-off shall take place at the centre ice face-off spot when play is stopped beyond the center red line. When play is stopped prior to the play reaching the center red line, the resulting face-off shall be conducted at the nearest face-off spot in the zone where the play was stopped.

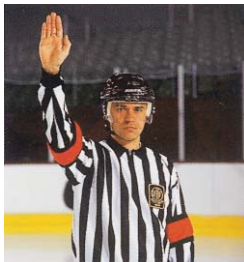

PLAYER CHANGE SIGNAL RULE 412

► This penalty shall be announced as a "Bench Minor Penalty for the Delay of Game - Violation of change of players after icing the puck".

► This penalty shall be announced as a "Bench Minor Penalty for the Violation of Change of Players from the Penalty Bench".

412 - CHANGE OF PLAYERS PROCEDURE DURING STOPPAGE OF PLAY

- a) Following a stoppage of play, the visiting team shall promptly place a line-up of players on the ice for play and no substitution shall be made until play has resumed. The home team may then make any desired substitution, which does not result in the delay of the game. If there is any undue delay by either team in changing lines, the Referee shall order the offending team or teams to take their positions immediately and shall not permit a line change.
- b) The procedure shall be carried out as follows:
 1. The Referee shall take his position for the start of the next play, and the Linesman dropping the puck shall proceed promptly to the location of the face-off.
 2. The Referee shall allow the visiting team **five seconds** to make their player changes.
 3. After the **five seconds**, the Referee shall raise his arm to indicate that the visiting team shall no longer make a player change.
 4. With the arm still up, the Referee shall allow the home team **five seconds** to make their player changes.
 5. After the **five seconds**, the Referee shall drop his arm to indicate that the home team shall no longer make a player change.
 6. As soon as the Referee drops his arm, the Linesman conducting the face-off shall blow the whistle, which signals both teams that they shall have no more than **five seconds** to line-up for the face-off.
 7. At the end of the **five seconds**, or sooner if the facing-off players are ready, the Linesman shall drop the puck. It shall not be the responsibility of the Linesman to wait for the players to come into position for the face-off.
- c) When a team attempts to make a player change after its allotted period of time, the referee shall send the player(s) back to the bench and issue a warning to the coach. Any subsequent infraction of this procedure at any time during the course of the game shall result in the team receiving a: **Bench Minor penalty** (see Rule 575). **NEW**
- d) Teams are not permitted to make player's substitution following a false face off, except when a penalty is assessed that affects the on ice strength of either team.
- e) Following a stoppage of play for an icing infraction, the offending team is prohibited from making any player change until play has resumed.
- f) A team that is in violation of this rule shall not be permitted to make any player substitutions prior to the ensuing face-off. Should the stoppage of play following the icing infraction coincide with a commercial time-out, or should the offending team elect to utilize their team time-out at this stoppage of play, they are still not permitted to make any player substitutions. However, a team shall be permitted to make a player substitution to replace a goalkeeper who had been substituted for an extra player, to replace an injured player or goalkeeper, or when a penalty has been assessed that affects their on-ice strength. The determination of players on ice will be made when the puck leaves the offending player's stick.
- g) If a team persists in changing players after they have iced the puck, and warned by the Referee, the Referee shall assess to the offending team a: **Bench Minor penalty** (2').

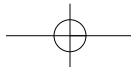

- ▶ This penalty shall be announced as a "Bench Minor Penalty for the Violation of Change of Players from the Penalty Bench".

- ▶ 1. This penalty shall be announced as a "Bench Minor Penalty for the Delay of the Game - Violation of Change of Goalkeepers during stoppage of Play".
- ▶ 2. **No warm-up** shall be permitted for a substitute goalkeeper.

- ▶ 1. If it is obvious that a player has sustained a serious injury, the Referee and/or the Linesman shall stop the play immediately.

- ▶ 1. **No warm-up** shall be permitted for the substitute goalkeeper.
- ▶ 2. In this case, neither of the two regular goalkeepers shall return to the game.
- ▶ 3. In IIHF competitions where 3 goalkeepers are registered and one of the two goalkeepers on the Game Sheet is incapacitated, the applicable IIHF By-Law applies.

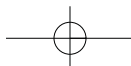

413 - CHANGE OF PLAYERS FROM THE PENALTY BENCH

A player serving a penalty, who is to be changed after the penalty has been served shall proceed at once, by way of the ice, and be at his own player's bench before any change can be made. **NEW**

- ▶ **Bench Minor** penalty

415 - CHANGE OF GOALKEEPERS DURING STOPPAGE OF PLAY

- a) During a stoppage of play, goalkeepers shall not be permitted to go to the players' bench except to be replaced or during a time out.
 - ▶ **Bench Minor** penalty (Rule 592)
- b) When a goalkeeper substitution has been made during a stoppage of play or a time-out, the goalkeeper who left the game may re-enter the game as soon as the play resumes.

416 - INJURED PLAYERS

- a) If a player is injured and cannot continue to play or go to the bench, the play shall continue until his team has secured possession of the puck, unless this team is in a scoring position.
- b) If a player other than the goalkeeper is injured or compelled to leave the ice during the game, he may retire and be replaced by a substitute, but play shall continue without the teams leaving the ice.
- c) If a penalized player has been injured he may proceed to the dressing room, and if he has been assessed a Minor, Major or Match penalty, the penalized team shall immediately put a substitute player on the penalty bench who shall serve the penalty without change, except by the injured penalized player if he is able to return.
- d) The injured penalized player shall not be eligible to play until his penalty has expired.
- e) If an injured player returns to play before his penalty has expired, the Referee shall assess additionally to this player a
 - ▶ **Minor** penalty (2')
- f) When play has been stopped due to an injured player, excluding the goalkeeper, the injured player shall leave the ice and shall not return to the ice until after play has resumed. Should he return earlier then a Minor penalty (2') is assessed (see Rule 554e) **NEW**

417 - INJURED GOALKEEPERS

- a) If a goalkeeper sustains an injury or becomes ill, he shall be ready to resume play immediately or be replaced by a substitute goalkeeper.
- b) If both goalkeepers of the team are incapacitated and unable to play, the team shall have **ten minutes** to dress another player in uniform as a goalkeeper.

419 - ICE CLEANING

- a) A Referee or a Linesman has the authority to remove a build up of snow around the goal post or on the goal line near the net. **NEW**
- b) If a goalkeeper deliberately piles snow or obstacles at or near his net that in the opinion of the Referee would tend to prevent the scoring of a goal he shall be assessed a:
 - ▶ **Minor** penalty (2')

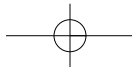

- ▶ 1. Playing time shall commence from the instant the puck is faced-off and shall stop when the whistle is blown.
- ▶ 2. If any unusual delay occurs within **five minutes** of the end of the first and second period, the Referee may order the next regular intermission to be taken immediately. When play resumes, the remaining time shall be played with the teams defending the same goal as before the intermission, after which time the teams change ends and resume playing the ensuing period without delay.
- ▶ 3. In open air rinks, teams shall change ends at the midway point of the third and overtime periods.
- ▶ 4. During the intermissions the ice shall be resurfaced.

- ▶ 1. With respect to goalkeepers, goalkeepers may be changed after each alternate shot has been taken, however, where a Shot has to be repeated, the same Goalkeeper must remain in the goal and the same player must repeat the shot until it is completed.
- ▶ 2. When a player and goalkeeper has been selected by their respective coaches to take a shot or defend the net against this shot, such player and/or goalkeeper cannot be changed if the Shot shall be repeated due to a violation or a foul committed by the goalkeeper unless such player and/or goalkeeper received an injury and cannot participate in the Penalty Shot Procedure. In this case the Coach may designate another player to take a Shot or the other goalkeeper to defend the net.

- ▶ No music can be played in the arena during a team Time-out



**TIME-OUT SIGNAL
RULE 422**

- ▶ **“Sudden Death”** means that the overtime period is finished when a team scores the first goal

420 - TIMING OF GAME

NEW

- a) The regular game shall consist of three 20 minute stop time periods and two 15-minute intermissions.
- b) The full 60 minute game duration shall be referred to as 'Regulation Time'.
- c) The teams shall change ends for each period of Regulation Time.

421 - OVERTIME PERIOD

NEW

In a game where a winner shall be declared, and the game is tied after Regulation Time, the game shall be prolonged by a sudden death overtime period. If no goal is scored in the overtime period, game winning shots shall be used to determine the winner.

422 - TIME-OUT

- a) Each team shall be permitted one **30 second time-out** during the course of Regulation Time or during Overtime. **NEW**
- b) During a normal stoppage of play, any player designated by the Coach may ask the Referee for the time-out. The Referee shall report the time out to the Scorekeeper.
- c) The players and goalkeepers of both teams, except for penalized players, are allowed to go to their respective benches
- d) Each team may take their time-out at the same stoppage of play, but the team taking the second time-out shall notify the Referee before the end of the first time-out.

430 - DETERMINING THE OUTCOME OF THE GAME

NEW

- a) The team scoring the greatest number of goals during Regulation Time of a regular game shall be declared the winner and shall be awarded with three points.
- b) If, at the end of Regulation Time of a regular game, the score for both teams is equal, each team will be awarded one point and the game will continue with a sudden death overtime period
- c) The winning team in the sudden death overtime period of a regular game will receive an additional point
- d) If neither team scores in the sudden death overtime period then Game Winning Shots will be applied
- e) The winning team in the Game Winning Shots of a regular game will receive an additional point
- f) In a playoff game where a winner shall be declared, the game shall be prolonged by a **“Sudden Death”** overtime period. If no goal is scored during the overtime period then game winning shots shall be used to determine the winner.

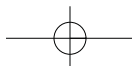

FACE-OFF SPOTS

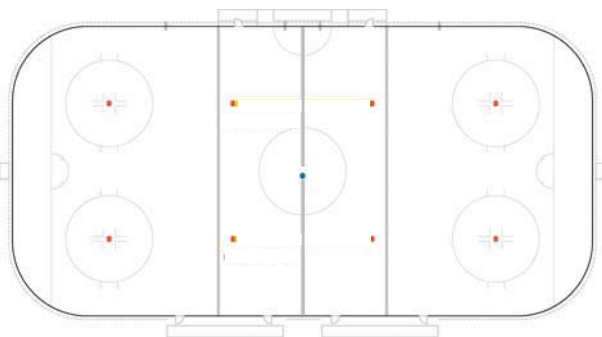

440 - FACE-OFFS

- a) A face-off shall be conducted **at the beginning of each period and after any stoppage NEW of play.**
- b) All face-offs will only be conducted at the nine designated face-offs spots
- c) Face-offs shall be conducted at the **center ice spot:**
 1. At the start of a period,
 2. After a goal scored,
 3. After an error by an official on icing,
 4. For premature substitution of a goalkeeper unless otherwise expressly provided by these rules (See Rule 411e)
- d) When a stoppage of play has been caused by any player of the attacking side in the attacking zone, the ensuing face-off shall be made in the neutral zone on the nearest face-off spot. If two rule violations are the reason for the stoppage of play (ie. high-sticking the puck and intentional off-side), the ensuing face-off location shall be determined as the spot that provides the least amount of territorial advantage to the offending team.
- e) When the play is stopped for any reason not specifically attributable to either team while the puck is in the neutral zone, the ensuing face-off shall be conducted at the nearest face-off spot outside the blue line whenever possible. When it is unclear as to which of the four face-off spots is the nearest, the spot that gives the home team the greatest territorial advantage in the neutral zone will be selected for the ensuing face-off.
- f) When an infringement of a rule has been committed by players of both sides in the play resulting in the stoppage, the ensuing face-off will be made at the nearest face-off spot in that zone
- g) When players are penalized at a stoppage of play so as to result in penalties being placed on the penalty time clock to one team, the ensuing face-off shall be conducted at one of the two end zone face-off spots in the offending team's end zone. There are only four exceptions to this application:
 1. When a penalty is assessed after the scoring of a goal - face-off at Centre Ice
 2. When a penalty is assessed at the end (or start) of a period - face-off at Centre Ice
 3. When the defending team is about to be penalized and the attacking players enter the attacking zone beyond the outer edge of the end zone face-off circles - face-off in the Neutral Zone
 4. When the team not being penalized ices the puck, the face-off in the neutral Zone outside the blue line of the team icing the puck
- h) When stoppage occurs between the end face-off spots and near end of the rink, the puck shall be faced-off at the end face-off spot on the side where the stoppage occurs unless otherwise expressly provided by these rules.
- i) When a goal is illegally scored as a result of a puck being deflected directly off an official anywhere in the defending zone, the resulting face-off shall be made at the end face-off spot in the defending zone.
- j) When the game is stopped for any reason not specifically covered in the official rules, the puck must be faced-off at a face-off spot in the zone nearest to where it was last played.
- k) Following a stoppage of play, should one or both defensemen who are the point players or any player coming from the bench of the attacking team, enter into the attack-

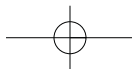

- ▶ 1. The whistle shall not be blown by the official to start play.
- ▶ 2. No substitution of players shall be permitted until the face-off has been conducted and play has resumed, except when a penalty is assessed that shall affect the on ice strength of either team.
- ▶ 3. If the player facing-off fails to take his proper position immediately when directed to do so by the official, the official may order him replaced for the face-off by another team mate on the ice.
- ▶ 4. If a player enters the face-off circle, the Referee or Linesman shall blow the whistle to re-face-off the puck, unless the non-offending team gains possession of the puck.
- ▶ 5. The Referee shall assess the corresponding **penalty(s)** or the infraction made by the player (See Rule 554g paragraph b).

OFFSIDE PASS SITUATIONS

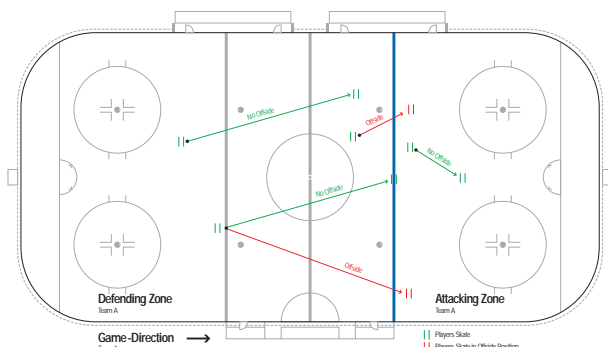

- ▶ 1. If a defending player carries or passes the puck into his defending zone while a player of the attacking team is in an offside position, no offside will be called.
- ▶ 2. An **intentional offside** is made for the purpose of causing a stoppage of play, regardless of the reason.

ing zone beyond the outer edge of the end zone face-off circle during an altercation, gathering or "scrum," the ensuing face-off shall take place in the neutral zone near the blue line of the defending team. This rule also applies when an icing, an intentional off-side, or a high-sticking the puck violation. Should any of the non-offending players enter into the attacking zone beyond the outer edge of the end zone face-off circle during an altercation, gathering or "scrum," the ensuing face-off shall take place in the neutral zone near the blue line of the defending team.

- l) For a violation of Rule 411e, the resulting face-off will take place at the center ice face-off spot when play is stopped beyond the center red line. When play is stopped prior to the center red line, the resulting face-off shall be conducted at the nearest face-off spot in the zone where the play was stopped.
- m) When play is stopped for an injured player, the ensuing face-off shall be conducted at the face-off spot in the zone nearest the location of the puck when the play was stopped. When the injured player's team has possession of the puck in the attacking zone, the face-off shall be conducted at one of the face-off spots outside the blue line in the neutral zone. When the injured player is in his defending zone and the attacking team is in possession of the puck in the attacking zone, the face-off shall be conducted at one of the defending team's end-zone face-off spots.

442 - PROCEDURE FOR CONDUCTING FACE-OFFS

- a) The Referee or the Linesman shall drop the puck between the sticks of the two players facing off.
- b) The players shall be positioned squarely facing their opponent's end of the rink, approximately one stick length apart, with the blade of their stick on the ice on the white part of the face-off spots.
- c) The player of the attacking team in his attacking half of the rink shall place his stick on the ice first followed immediately by the player of the defending team.
- d) However, when the face-off is at the centre ice spot the player of the visiting team shall place his stick first on the ice.

450 - OFFSIDES

- a) Players of an attacking team **shall not precede the puck** into their attacking zone.
- b) The determining factors in deciding an offside are:
 1. The **player's skates position** - player is offside when both skates are completely over the blue line in his attacking zone before the puck completely crosses the line,
 2. The **puck position** - the puck shall have completely crossed the blue line into the attacking zone.
 3. If a player is propelling the puck and crosses the line ahead of the puck while skating backward, the player is not offside provided he is actually in control of the puck and has both skates in the neutral zone before crossing the blue line

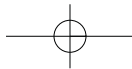

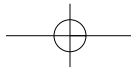

- ▶ 1. The attacking zone shall be completely clear of attacking players before the delayed offside can be nullified with the puck still in the attacking zone.
- ▶ 2. **"Immediately"** means that the attacking players shall not touch the puck, or attempt to gain possession of a loose puck, or force the defending puck carrier further back in the zone.
- ▶ 3. In this second case, when the Linesman drops his arm, any attacking player may re-enter his attacking zone.

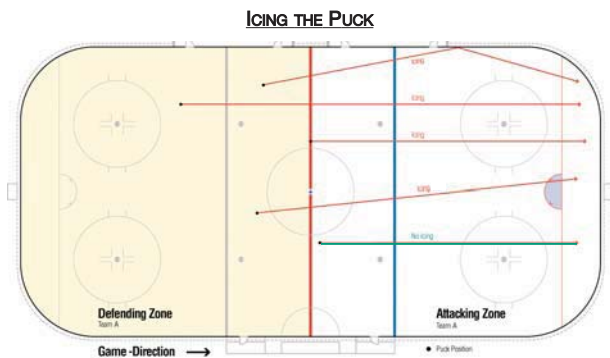

- ▶ 1. If the Linesmen have erred in calling an icing, the puck shall be faced-off on the center ice face-off spot.
- ▶ 2. The purpose of this section is to enforce continuous action and both Referee and Linesmen should interpret and apply the rule to produce this result.
- ▶ 3. **"Short Handed"** means that due to a penalty(s), the team must be below the numerical strength of its opponents on the ice.

- c) In violation of this rule, play shall be stopped and a face-off shall be conducted:
 1. At the nearest neutral zone face-off spot, if the puck was carried over the blue line by the attacking player.
 2. At the nearest face-off spot where the pass or shot originated when the puck was passed or shot over the blue line by the attacking player. **NEW**
 3. At the end face-off spot in the defending zone of the offending team if, in the opinion of the Linesman or Referee, a player has intentionally caused an offside.
 4. At the end zone face-off spot in the defending zone of the offending team, if the puck was passed or shot by the attacking player from his defending zone.

451 DELAYED OFFSIDE PROCEDURE

If an attacking player precedes the puck into the attacking zone, but a defending player is able to play the puck, the Linesman shall raise his arm to signal a **"Delayed Offside"**, except if the puck has been shot on goal causing the goalkeeper to play the puck.

The Linesman shall drop his arm to nullify the offside violation and allow the play to continue if:

1. The defending team either passes or carries the puck into the neutral zone,
2. Or, all attacking players **immediately** clear the attacking zone by making skate contact with the blue line.

460 - ICING THE PUCK

- a) For the purpose of this rule, the centre red line divides the ice rink into two halves. The point of last contact with the puck by the team in possession shall be used to determine whether or not icing has occurred.
- b) Should a player of a team equal or superior in numerical strength shoot, bat or deflect the puck from **his own half of the ice beyond the goal line** of the opposing team, play shall be stopped and icing shall be called.
- c) A face-off will take place at the end zone face-off spot of the offending team nearest to where they last touched the puck. **NEW**
- d) **No icing** shall be called:
 1. If the puck enters the goal - the goal is allowed,
 2. If the offending team is **"Short Handed"** at the instant the puck is shot,
 3. If the puck touches any part of an opposing player, including the goalkeeper, before crossing the goal line,
 4. If the puck is iced directly from a player participating in a face-off,
 5. If, in the opinion of the Linesman, any player from the other team, except the goalkeeper, is able to play the puck before it crosses the goal line.
 6. Once the goalkeeper leaves his goal crease or when the goalkeeper is outside his goal crease during icing situation and moves in the direction of the puck.
- e) Following a stoppage of play for an icing infraction, the offending team is prohibited **NEW** from making any player change until play has resumed.

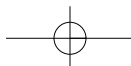

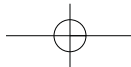

- ▶ This penalty shall be announced as a "Bench Minor Penalty for the Delay of the Game - Violation of Change of Players after Icing the Puck".

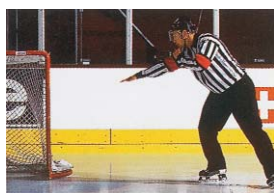

PUCK IN THE NET

- ▶ 1. Only one goal can be awarded to one team at any single stoppage during the course of any game.
 - ▶ 2. The 'lacrosse-like' move whereby the puck is picked up on the blade of the stick and 'whipped' into the net shall be permitted provided the puck is not raised above the height of the shoulders at any time and when released, is not carried higher than the crossbar.
 - ▶ 3. All such calls shall be based strictly on the judgement of the Referee
-
- ▶ 1. No goal shall be disallowed after the face-off immediately following the scoring of that goal.
 - ▶ 2. The goal crease is defined as a **volume**, extending from the crease area on the ice up to **1.27 m** above the ice surface.
 - ▶ 3. **"Contact"** whether or otherwise, between a goalkeeper and an attacking player may be with the stick or any part of the body.
 - ▶ 4. All such calls shall be based strictly on the judgement of the Referee

- f) A team that is in violation of this rule shall not be permitted to make any player substitutions prior to the ensuing face-off. Should the stoppage of play following the icing infraction coincide with a commercial time-out, or should the offending team elect to utilize their team time-out at this stoppage of play, they are still not permitted to make any player substitutions. However, a team shall be permitted to make a player substitution to replace a goalkeeper who had been substituted for an extra player, to replace an injured player or goalkeeper, or when a penalty has been assessed that affects their on-ice strength. The determination of players on ice will be made when the puck leaves the offending player's stick **NEW**
- g) If a team persists in changing players after they have iced the puck, and warned by the Referee, the Referee shall assess to the offending team a **NEW**
 - ▶ **Bench Minor** penalty (2')

470 - DEFINITION OF A GOAL

A goal shall be allowed:

1. When the puck has been put between the goal posts below the crossbar and entirely across the goal line by the stick of a player of the attacking team.
2. If the puck has been put into the goal net in any way by a player of the defending team.
3. If the puck has been deflected into the goal net from the shot of an attacking player by striking any part of a teammate.
4. If a player of the attacking team has been physically interfered by the action of any defending player so as to cause him to be in the goal crease when the puck enters the goal net, unless if in the opinion of the Referee, he had sufficient time to get out of the crease.
5. If the puck should become loose in the goal crease and then put into in the goal by the stick of the attaching player,
6. When the puck deflects directly off the skate of an attacking or defending player.
7. If an attacking player being in the goal crease at the moment the puck crosses a goal line and in **NO WAY** affect the goalkeeper's ability to make a save, unless the cases describing in Rule 471.

471 - DISALLOWING A GOAL

a) **No goal** shall be allowed:

1. If an attacking player deliberately kicks, throws or bats with the hands or otherwise directs the puck by any means other than his stick into the goal net even if the puck has been further deflected by any player, goalkeeper or official,
2. If an attacking player contacted the puck with the stick above the cross bar,
3. If the puck has been directly deflected into the goal net off an official,
4. If an attacking player stands or holds his stick in the goal crease when the puck enters the goal net, unless he has been physically interfered with, by the action of any defending player so as to cause him to be in the goal crease when the puck enters the goal net, unless if in the opinion of the Referee, he had sufficient time to get out of the crease or unless Rule 470 applies.
5. If the goal net has been displaced from its normal position, or the frame of the goal net is not completely flat on the ice.



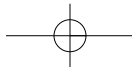

- ▶ 1. Only one point shall be awarded to any one player on a goal.
- ▶ 2. Two assists may be awarded when a player scores after a rebound off of the goalkeeper.
- ▶ 3. In the case of an obvious error in awarding a goal or assist, the error shall be corrected promptly, but changes shall not be made once the Referee has signed the **Official Game Sheet**.

- 6. If an attacking player initiates contact with the goalkeeper, incidental or otherwise, while the goalkeeper is in his goal crease and a goal is scored.
 - 7. If an attacking player initiates any contact with the goalkeeper, other than incidental contact, while goalkeeper is outside his goal crease and a goal is scored.
 - 8. Where an attacking player enters or takes a position within the goal crease, so as to obstruct the goalkeeper's vision and impair his ability to defend his goal net and a goal is scored.
 - 9. Where a goalkeeper has been pushed into the goal net together with the puck after making a stop. If applicable, appropriate penalties shall be assessed.
- b) Where the puck is under the player who is in or around the goal crease (deliberately or otherwise), a goal cannot be scored by pushing this player together with the puck into the goal net. If applicable, the appropriate penalties shall be assessed, including the Penalty Shot (See Rule 557).

472 - GOAL AND ASSIST AWARDED TO THE PLAYER

- a) A "**Goal**" shall be credited in the scoring records to the player who propelled the puck into the opponent's net.
- b) Each goal shall count **one point** in the player's statistical record.
- c) When a goal has been scored, an "**Assist**" shall be credited to the player(s) taking part in the play immediately preceding the action.
- d) No more than two assists can be given on any goal.
- e) Each assist shall account for **one point** in the player's statistical record.

480 - PUCK OUT OF BOUNDS

NEW

When the puck goes outside the playing area or strikes any obstacles, other than the boards or protective glass above the ice surface, the play shall be stopped and the face-off shall take place at the nearest point on the face-off spot where the puck was shot or deflected, unless expressly provided in these rules.

481 - PUCK ON THE NET

When the puck is lodged in the outside netting of the goal net for more than **three seconds** or frozen against the goal net between opposing players, the Referee shall stop the play and face-off the puck:

- 1. At the nearest end zone face-off spot if, in the opinion of the Referee, the stoppage **NEW** has been caused by an defending player.
- 2. At the nearest neutral zone face off-spot if, in the opinion of the Referee, the stoppage has been caused by an attacking player.

482 - PUCK OUT OF SIGHT

NEW

Should a scramble take place or a player accidentally fall on the puck and the puck is out of sight of the Referee, he shall immediately stop the play, and the puck shall be faced-off at the nearest face-off spot to where the play has been stopped, unless provided for in the rules.

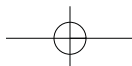

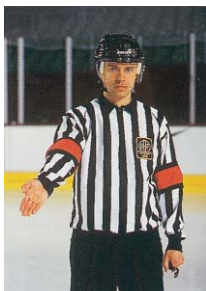

**HAND PASS SIGNAL
RULE 490**

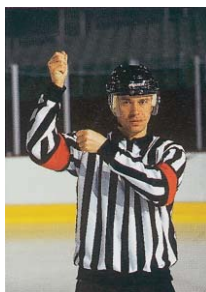

**HIGH STICKING THE PUCK SIGNAL
RULE 492**

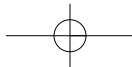

483 - ILLEGAL PUCK

If, at any time, while play is in progress, a puck other than the one legally in play shall appear on the playing surface, the play shall not be stopped until the play then in progress is completed by change of **possession**.

484 - PUCK STRIKING AN OFFICIAL

Play shall not be stopped because the puck touches an official except when the puck has entered the goal.

490 - STOPPING/PASSING THE PUCK WITH HANDS

A player shall be permitted to stop or bat the puck in the air with the open hand or push it along the ice with his hand and the play shall not be stopped, unless in the opinion of the Referee, the player has deliberately directed the puck to a team-mate or has allowed his team to gain an advantage and subsequently possession and control of the puck is obtained by a player of the offending team, either directly or deflected off any player or official. A player shall be permitted to catch the puck out of the air but must immediately place it or knock it down to the ice. If he catches it and skate with it, either to avoid a check or to gain a territorial advantage over his opponent he shall be assessed a:

▶ **Minor** penalty (2') (see Rule 559)

- a) When a hand pass violation has occurred the play shall be stopped and the ensuing face-off shall take place at the nearest face off spot in the zone where the offence occurred, unless the offending team gains a territorial advantage, then the face-off shall be at the nearest face off spot in the zone where the stoppage of play occurred unless otherwise covered in the rules. **NEW**
- b) If a teammate of such a player obtains possession of the puck in his Defending Zone, the Referee shall not stop the play provided the hand pass is completed before the player and puck leave the zone. However when the puck is passed with the hand from a player in the Neutral Zone to a teammate in his Defending Zone, the Referee shall stop the play with the Face-off at the face-off spot in the Defending Zone. **NEW**
- c) If a teammate of such player obtains possession of the puck in his Attacking Zone, the Referee shall stop the play, with the Face-off at the Neutral zone face-off spot outside the Attacking zone.
- d) A goal shall be disallowed if the puck was batted by an attacking player even deflected into the goal by any player or his stick, goalkeeper or official into the goal.
- e) A goal shall be disallowed if the puck was batted by an attacking player even if deflected into the goal by any player or his stick or skate, goalkeeper or official into the goal.

492 - HIGH STICKING THE PUCK

- a) **Stopping or batting the puck with the stick above the height of the shoulders is prohibited**, and the play shall be stopped, unless:
 1. The puck is batted to an opponent in which case the play shall continue and the Referee shall give the "Wash Out" signal.
 2. A player of the defending team bats the puck in his own goal, in which case the goal is allowed.

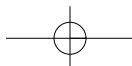



WASH-OUT SIGNAL

- b) If the puck has been high-sticked by an attacking player in his Attacking Zone the face-off shall take place at the nearest spot in the Neutral Zone.
- c) If the puck has been high stuck by a player in his Defending Zone or in the Neutral Zone, the face-off shall take place at the nearest Defending Zone face-off spot. **NEW**
- d) No goal can be scored when the puck is high stuck into the net with a stick of the attacking team where the point on the stick where the puck hit the stick is above the height of the crossbar and the puck was propelled into the net. **NEW**

493 - INTERFERENCE BY SPECTATORS

- a) In the event that objects are thrown on to the ice, which interferes with the progress of the game, the Referee shall stop the play and the puck shall be faced-off at the nearest face-off spot where the play was stopped. **NEW**
- b) In the event of a player being held or interfered with by a spectator, the Referee or the Linesman shall stop the play. If the team of the player interfered with is in possession of the puck, the play shall be allowed to be completed.
 - ▶ **Report** to the Proper Authorities.

Table of Penalties

Penalty	Players		Goalkeepers		Remarks		
	Player out for	Served on the penalty bench by	Goalkeeper out for	Served on the penalty bench by	Recorded on game sheet	Observations	Coincidental- penalties
MINOR	2 Minutes	Offender	-	Player on the ice	2 Minutes	May expire on a goal	May apply
BENCH MINOR	2 Minutes	Player on the ice	Not applicable	-	2 Minutes	May expire on a goal	May apply
MAJOR	Balance of the game	Any player except the offender for 5 minutes	Balance of the game	Player on the ice for 5 minutes	5 Minutes	-	May apply
MISCONDUCT	10 Minutes	Offender	-	Player on the ice	10 Minutes	-	-
GAME MISCONDUCT	Balance of the game	None	Balance of the game	None	20 Minutes	Report	-
MATCH	Balance of the game	Any player except the offender for 5 minutes	Balance of the game	Player on the ice for 5 minutes	25 Minutes	Report	May apply
PENALTY SHOT	-	-	-	-	Penalty shot	-	-

SECTION 5 - PENALTIES

500 - PENALTIES - DEFINITION AND PROCEDURES

Penalties are divided into the following categories showing time to be served:

- | | |
|----------------------------|-------|
| 1. MINOR PENALTY | (2') |
| 2. BENCH MINOR PENALTY | (2') |
| 3. MAJOR PENALTY | (5') |
| 4. MISCONDUCT PENALTY | (10') |
| 5. GAME MISCONDUCT PENALTY | (GM) |
| 6. MATCH PENALTY | (MP) |
| 7. PENALTY SHOT | (PS) |

All penalties shall be **actual playing time**.

- Penalties imposed after the end of the game shall be reported by the Referee on the Official Game Sheet.
- Some rules state that the Manager or Coach shall designate a player to serve a penalty. If they refuse to do so, the Referee has the authority to name any player of the offending team to serve the penalty.
- When the Minor or Major penalties of two players of the same team terminate at the same time, the Captain of that team shall designate to the Referee which player shall return on the ice first. The Referee shall then instruct the Scorekeeper accordingly.
- For a Game Misconduct penalty, a total of **20 minutes** shall be recorded on the **NEW** Game Sheet against the penalized player or goalkeeper. For a Match penalty, a total of **25 minutes** shall be recorded on the Game Sheet against the penalized player or goalkeeper.
- For all Game Misconduct Penalties and Match penalties the Referee shall **file a NEW written report** to the Proper Authorities immediately following the game.

501 - MINOR PENALTY

For a **Minor penalty**, any player, other than the goalkeeper, shall be ruled off the ice for **two minutes** and no substitution shall be permitted.

When a player is assessed a Minor and a Major penalty at the same time, the Major penalty shall be served first. This applies when both penalties are imposed on the **SAME** player (see Rule 513)

- ▶ 1. The designated player shall take his place on the penalty bench promptly and serve the penalty, as it was a Minor penalty imposed to him.
- ▶ 2. “Short Handed” means that, due to a penalty(s), the team shall be below the numerical strength of its opponents on the ice at the time the goal is scored.
- ▶ 3. This rule does not apply when a goal is scored on a Penalty Shot.
- ▶ When a player is assessed a **Major and a Minor penalty** at the same team, the Major penalty shall be served first. This applies when both penalties are imposed on the same player (see Rule 513).
- ▶ When a player is assessed a **Minor or Major penalty and a Misconduct penalty** at the same time, the penalized team shall immediately put a substitute player on the penalty bench to serve the Minor or Major penalty with out change.

- ▶ 1. A **Game Misconduct penalty** does not incur automatic suspension, except for that game, but the Proper Authorities shall have the power to suspend the player or the team official from participating in further games.
- ▶ 2. In championships and tournament games, any player or team official assessed his second Game Misconduct Penalty shall be automatically suspended for his team's next championship or tournament games.
- ▶ 1. The player shall be ordered to the dressing room and a substitute player shall be permitted to replace him **after five minutes** playing time has elapsed.
- ▶ 2. A player or team official incurring a **Match penalty** shall be awarded an **automatic further suspension**, which means that he shall be suspended for the next game as a minimum, and his case shall be dealt with by the Proper Authorities.

502 - BENCH MINOR PENALTY

- a) For a **Bench Minor penalty**, any player who was on the ice at the time of the infraction, **NEW** other than the goalkeeper of the penalized team, designated by the Manager or the Coach through the Captain, shall be ruled off the ice for two minutes and no substitution shall be permitted.
- b) If, while a team is “Short Handed” because of one or more **Minor or Bench Minor penalties**, the opposing team scores a goal, the first of such penalties shall automatically terminate, unless such penalty was assessed at the same time as an opposing player's penalty which originally caused both teams to play one player short, in which case the next minor or bench minor penalty assessed to the scored upon team shall terminate.

503 - MAJOR PENALTY

For a **Major penalty**, any player, including the goalkeeper, shall be ruled off the ice **for the balance of the game** (Game Misconduct penalty) and substitution shall be permitted after five minutes.

504 - MISCONDUCT PENALTY

- a) For his first **Misconduct penalty**, any player, other than the goalkeeper, shall be ruled off the ice for ten **minutes** and immediate substitution shall be permitted. The player whose Misconduct penalty has expired shall stay on the penalty bench until the next stoppage of play.
- b) For his second **Misconduct penalty** any player, including the goalkeeper, shall automatically be ruled off the ice for the **balance of the game** (Game Misconduct penalty) and immediate substitution shall be permitted.

505 - GAME MISCONDUCT PENALTY

For a **Game Misconduct penalty**, any player, including the goalkeeper or team official, shall be ruled off the ice and ordered to the dressing room **for the balance of the game** and immediate substitution for the player or the goalkeeper shall be permitted.

507 - MATCH PENALTY

For a **Match penalty**, any **player, goalkeeper or team official** shall be ruled off the ice and ordered to the dressing room for the **balance of the game** and substitution shall be permitted after **five minutes**. **NEW**

- ▶ 1. In a **"Breakaway"** situation, when a player in **"Control of the Puck"** outside his own Defending Zone, with no opponent to pass other than the goalkeeper (See also Rule 533 and 539) is fouled from behind, thus preventing a reasonable scoring opportunity, the Referee shall award to the non-offending team a **Penalty Shot**.
- ▶ 2. If, when the opposing goalkeeper has been removed from the ice and a player in **"Control of the Puck"** outside his own Defending Zone, with no opponent to pass between him and the opposing goal net (See also Rule 533 and 539) is fouled from behind, the Referee shall award to the non-offending team a **Goal**.

For Rule 509:

- ▶ 1. If the foul upon which the Penalty Shot is based occurred during actual playing time, the Penalty Shot shall be awarded and taken immediately in the usual manner, notwithstanding any delay occasioned by a slow whistle by the Referee. In this case, the play shall be permitted to be completed, which delay results in the expiry of the regular playing time in any period.
- ▶ 2. If the goalkeeper leaves his crease before the player has touched the puck, or commits any foul, the Referee shall raise his arm but allow the shot to be completed. If the shot fails, he shall permit the Penalty Shot to be taken again. If the goalkeeper leaves the goal crease too early, the Referee shall issue a WARNING the first time and a new Penalty Shot. issue a Misconduct penalty the second time and a new Penalty Shot, and award a Goal the third time.
- ▶ 3. The goalkeeper shall attempt to block the shot in any manner, except by throwing his stick or any other object, in which case a goal shall be awarded.
- ▶ 4. When the Penalty Shot is taken, if any player of the opposing team interferes or distracts the player taking the shot, and because of such action the shot fails, the Referee shall allow a second Penalty Shot and assess a Misconduct penalty on the offending player.
- ▶ 5. The time required for taking a Penalty Shot shall not be recorded in the actual playing time in any period.
- ▶ 6. The 'spin-o-rama' type of move where the player completes a 360° turn as he approaches the goal, shall be permitted as it involves continuous forward motion.
- ▶ 7. Should two Penalty Shots be awarded to the same team at the same stoppage of play (two separate fouls), only one goal can be scored or awarded at a single stoppage of play. Should the first Penalty Shot result in a goal, the second Penalty Shot would not be taken but the appropriate penalty would be assessed and served for the infraction committed.
- ▶ 8. Cradling the puck on the blade of the stick (like lacrosse) above the normal height of the shoulders shall be prohibited and a stoppage of play shall result.
- ▶ 9. If this is done by a player on a Penalty Shot or a Game Winning Shot, the play will be immediately blown dead by the Referee and the play will be considered complete.
- ▶ 10. When a player and goalkeeper has been selected by their respective coaches to take a shot or defend the net against this shot, such player and/or goalkeeper cannot be changed if the Shot shall be repeated due to a violation or a foul committed by the goalkeeper unless such player and/or goalkeeper received an injury and cannot participate in the Penalty Shot Procedure. In this case the Coach may designate another player to take a Shot or the other goalkeeper to defend the net.

508 - PENALTY SHOT

- a) Five conditions are required to award a **Penalty Shot** for a player being fouled from behind:
 1. The infraction must take place when the puck is outside of the player's defending zone (completely across the blue line).
 2. The attacking player must be in possession and have control of the puck.
 3. The infraction must have been committed from behind.
 4. The attacking player in possession and control of the puck must have been denied a reasonable scoring opportunity.
 5. The player in possession and control of the puck must have had no opposing players to pass to other than the goalkeeper.

b) A penalty shot can be awarded in those situations **where a goalkeeper fouls a player in a break-away** situation, regardless if the infraction takes place from behind or not. **NEW**

c) If the infraction involves any other penalty, the shot shall be awarded and the penalty shall be assessed regardless of whether the Penalty Shot results in a goal or not.

509 - PENALTY SHOT PROCEDURE

- a) In cases where a player was fouled in a manner that warrants a penalty shot, the player fouled shall be designated to take the penalty shot. If the fouled player is injured on the play, the Captain shall designate any non-penalized player who was on the ice at the time of the infraction to take the penalty shot. **NEW**
- b) In cases where the player fouled is not identifiable, the Coach or the Captain of the non-offending team selects and reports to the Referee the number of any non-penalized player who was on the ice at the time of the infraction, who shall take the shot. **NEW**
- c) The Referee shall cause to be announced the name and number of the player taking the penalty shot, who cannot be a player serving a penalty or have been assessed a delayed penalty.
- d) The players of both teams shall withdraw to their player benches. **NEW**
- e) The Referee shall place the puck on the center spot. Only a goalkeeper shall defend against the Penalty Shot.
- f) The goalkeeper shall stay in his crease until the player has touched the puck.
- g) The player shall, on instruction of the Referee, play the puck and proceed towards his opponent's goal line and attempt to score on the goalkeeper.
- h) If the player misses the puck and does not touch the puck on the way past it as it sits on the centre Face-off dot, then the player can return and continue with the Penalty Shot. **NEW**
- i) Once the puck is shot the play shall be considered complete, and no goal can be scored by a second shot of any kind.
- j) If a goal is scored, the face-off shall take place at center ice.
- k) If no goal is scored, the face-off shall take place at either of the end zone face-off spots in which the Penalty Shot has been attempted.

- ▶ 1. All penalties imposed to a goalkeeper, regardless of who serves the penalty, shall be charged in the records against the goalkeeper.
- ▶ 2. Any additional penalties which were assessed to the goalkeeper at the same stoppage of play apply and shall be served by another player of his team who was on the ice at the time the play was stopped to assess penalty for the infraction.

NEW ▶ In the application of this rule, Minor and Bench Minor penalties are considered as identical.

510 - SUPPLEMENTARY DISCIPLINE

In addition to the suspension imposed under these rules, the proper authorities may, at any time after the conclusion of the game, investigate any incident and may assess additional suspensions for any offence committed on or off the ice at any time before during and after the game, whether or not such offences have been penalized by the Referee.

511 - GOALKEEPER PENALTY PROCEDURE

A goalkeeper never goes to the penalty bench

- a) For Minor, or first Misconduct penalties assessed to the goalkeeper:
 - ▶ The goalkeeper **continues to play**.
 - ▶ His penalty shall be served by another player of his team who was on the ice at the time the play was stopped to assess the penalty for the infraction and was designated by the Manager or Coach through the Captain
- b) For Major, Game Misconduct or Match penalties, the goalkeeper shall be ruled off the ice for the **balance of the game**. He shall be replaced by the substitute goalkeeper, if available, or otherwise by a member of his team, who shall be permitted 10 minutes to dress in the goalkeeper's full equipment.
- c) In case of Major or Match penalties the 5 minute Penalty shall be served by another player of his team who was on the ice at the time the play was stopped to assess the penalty for the infraction and is designated by the Manager or Coach through the Captain.

512 - COINCIDENTAL PENALTIES

- a) When an equal number of identical penalties (Minor, Major or Match) are assessed to **both teams at the same stoppage of play**, such penalties shall be known as
 - ▶ **Coincidental Penalties**
- b) When such penalties are assessed, immediate substitutions shall be made for those penalties and they shall not be taken into account for the purpose of delayed penalties
- c) In the case where the penalized players remain in the game, they shall take their place on the penalty bench and shall not leave until the first stoppage of play following the expiry of their respective penalties.

There is **only one exception to this rule** (see section 'd' of this rule):

- d) When **both teams are at Full Strength** on the ice, **No Substitution** shall be permitted if only **one Minor** penalty is assessed to **one** player on **each** team at the **same stoppage of play**.

- ▶ 1. If the penalties of two players of the same team expire at the same time, the Captain of the team shall designate to the Referee which of the players will return to the ice first, and the Referee shall instruct the Scorekeeper accordingly.
- ▶ 2. When a Major and a Minor penalty are imposed at the same time on two or more players of the same team, the Scorekeeper shall record the Minor penalty as being the first of such penalties.

This also applies when the two penalties are imposed on **different** players (see Rule 501).

- ▶ 1. **“Possession”** means that the puck shall have come into the possession of, and has been controlled or intentionally directed by, a player or goalkeeper of the opposing team, or has been frozen.

No rebound off of any player of the offending team or goalkeeper, or off the goal or boards, shall be considered as possession.

- ▶ 2. If after the Referee has signalled a penalty, but before the whistle has been blown, the puck enters the goal of the non-offending team as the direct result of the action of the player of the offending team, the goal shall not be allowed and the penalty signalled shall be imposed.

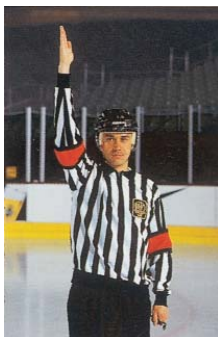

DELAYED CALLING OF PENALTY

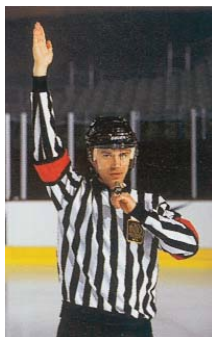

CALLING OF PENALTY

513 - DELAYED PENALTY

This rule applies only when Minor, Bench Minor, Major or Match penalties are involved.

- a) If a third player of any team is assessed a penalty while two players of his team are serving penalties, his penalty time shall not commence until the penalty time of one of the other players has elapsed.
- b) The player shall proceed at once to the penalty bench, but shall be replaced on the ice by a substitute.
- c) When any team has three or more players serving penalties at the same time, and because of the delayed penalty rule a substitute for the third offender is on the ice, none of the three penalized players shall return to the ice until play has been stopped, unless by reason of the expiration of his penalty the penalized team is allowed to have more than four players including the goalkeeper on the ice, in which case the penalized players shall be permitted to return in the order of their penalties.

514 - CALLING OF PENALTIES

Should an infraction of the rules be committed which would call for a penalty:

- a) If the team of the offending player is in possession of the puck, the Referee shall immediately blow the whistle and assesses the penalty. The face-off shall take place at one of the two end zone face off spots in the offending team's end zone (See Rule 440g) **NEW**
- b) If the team of the offending player is NOT in possession of the puck, the Referee shall raise his arm, signifying the calling of a penalty and, upon possession of the puck by the offending team the Referee shall blow the whistle and assess the penalty. **NEW**
- c) If, after the Referee has raised his arm, a goal is scored in any manner against the non-offending team as a result of an action of that team, the goal shall be allowed and a penalty shall be imposed in a normal manner.
- d) If, after the Referee has raised his arm, a goal is scored by the non-offending team, the goal shall be allowed and the first Minor penalty shall not be assessed. All other penalties shall be assessed. If the offending team is already short handed, the first minor or bench minor penalty being served shall be terminated and all penalties being signalled shall be assessed in the normal manner. **NEW**

- ▶ **“Rolling”** an opponent, who is the puck carrier, along the boards when he is endeavouring to go through an opening, is not boarding.

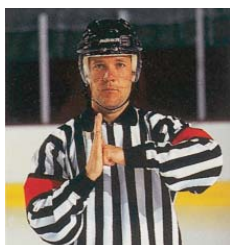

BOARDING SIGNAL
RULE 520



BOARDING

- ▶ 1. **“Butt-ending”** identifies the act of a player who uses the shaft of the stick above the upper hand to check an opposing player.
- ▶ 2. **“Attempt to Butt-end”** shall include all cases when a butt-end gesture is made but no contact is made.



BUTT-ENDING

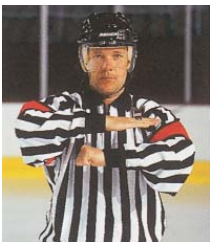

BUTT-ENDING SIGNAL
RULE 521

- ▶ 1. **“Charging”** shall mean the action of a player who as a result of distance travelled, shall violently check an opponent. “Charging” shall be the result of a check into the boards, into the goal or in open ice.
- ▶ 2. A player, who makes physical contact with an opponent after the whistle has been blown, and if, in the opinion of the Referee, the player had sufficient time after the whistle to avoid such contact, shall be assessed, at the discretion of the Referee, a penalty for **“Charging”**.
- ▶ 3. A goalkeeper is not “Fair Game” just because he is outside of the goal crease area. A penalty for a **“Interference”** or **“Charging”** shall be called in every case where an opposing player makes unnecessary contact with a goalkeeper.



CHARGING SIGNAL
RULE 522

FOULS AGAINST PLAYERS

520 - BOARDING

a) A player who body checks, elbows, charges or trips an opponent in such a manner that it causes the opponent to be thrown violently into the boards, shall be assessed at the discretion of the Referee, a:

- ▶ **Minor** penalty (2')
- or
- ▶ **Major** penalty + **Automatic Game Misconduct** penalty (5'+GM)
- or
- ▶ **Match** penalty (MP)

b) A player who injures his opponent as a result of boarding shall be assessed at the discretion of the Referee a:

- ▶ **Major** penalty + **Automatic Game Misconduct** penalty (5'+GM)
- or
- ▶ **Match** penalty (MP)

521 - BUTT-ENDING

a) A player who attempts to butt-end an opponent shall be assessed a:

- ▶ **Double Minor** penalty + **Misconduct** penalty (2'+2'+10')

b) A player who butt-ends an opponent shall be assessed at the discretion of the Referee, a:

- ▶ **Major** penalty+ **Automatic Game Misconduct** penalty (5'+GM)
- or
- ▶ **Match** penalty (MP)

c) A player who injures his opponent by a butt-ending shall be assessed a:

- ▶ **Match** penalty (MP)

522 - CHARGING

a) A player who runs, jumps or charges an opponent or who runs, jumps or charges the opposing goalkeeper in his crease shall be assessed, at the discretion of the Referee, a:

- ▶ **Minor** penalty (2')
- or
- ▶ **Major** penalty+ **Automatic Game Misconduct** penalty (5'+GM)
- or
- ▶ **Match** penalty (MP)

b) A player who injures his opponent as a result of charging shall be assessed, at the discretion of the Referee, a:

- ▶ **Major** penalty + **Automatic Game Misconduct** penalty (5'+GM)
- or
- ▶ **Match** penalty (MP)

- ▶ 1. A check from behind is a check delivered on a player who is not aware of the impending hit, is unable to protect himself and contact is made on the back part of the body.
- ▶ 2. However, if a player intentionally turns his body to create contact, this would not be classified as check from behind.

**CHECKING FROM
BEHIND SIGNAL
RULE 523**

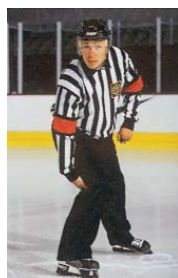

**CLIPPING SIGNAL
RULE 524**

- ▶ “Clipping” is the act of throwing the body across or below the knee of an opponent, charging, or falling into the knees of an opponent after approaching him from behind, side or front.



CLIPPING

- ▶ A “Cross-check” is a check delivered with both hands on the stick and no part of the stick on the ice.

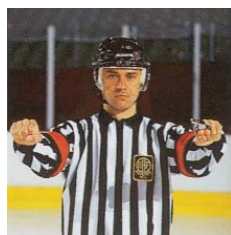

**CROSS-CHECKING SIGNAL
RULE 525**



CROSS-CHECKING

523 - CHECKING FROM BEHIND

a) A player who runs, jumps, charges or hits in any manner an opponent from behind shall be assessed, at the discretion of the Referee, a:

- ▶ **Minor penalty + Automatic Misconduct penalty** (2'+10')
- or
- ▶ **Major penalty + Automatic Game Misconduct penalty** (5'+GM)
- or
- ▶ **Match penalty** (MP)

b) A player who injures an opponent as result of checking from behind shall be assessed, a:

- ▶ **Match penalty** (MP)

524 - CLIPPING

a) A player who delivers a check in a clipping manner or lowers his own body position to deliver a check on or below an opponents knees, shall be assessed at the discretion of the Referee a:

- ▶ **Minor penalty** (2')
- or
- ▶ **Major penalty + Automatic Game Misconduct penalty** (5'+GM)
- or
- ▶ **Match penalty** (MP)

b) A player who injures his opponent by a clipping action, shall be assessed at the discretion of the Referee a:

- ▶ **Major penalty + Automatic Game Misconduct penalty** (5'+GM)
- or
- ▶ **Match penalty** (MP)

525 - CROSS-CHECKING

a) A player who cross-checks an opponent shall be assessed, at the discretion of the Referee, a:

- ▶ **Minor penalty** (2')
- or
- ▶ **Major penalty + Automatic Game Misconduct penalty** (5'+GM)
- or
- ▶ **Match penalty** (MP)

b) A player who injures an opponent by cross-checking shall be assessed at the discretion of the Referee a:

- ▶ **Major penalty + Automatic Game Misconduct penalty** (5'+GM)
- or
- ▶ **Match penalty** (MP)



**ELBOWING SIGNAL
RULE 526**



ELBOWING

526 - ELBOWING

a) A player who uses his elbow to foul an opponent shall be assessed at the discretion of the Referee a:

- ▶ **Minor** penalty (2')
- or
- ▶ **Major** penalty + **Automatic Game Misconduct** penalty (5'+GM)
- or
- ▶ **Match** penalty (MP)

b) A player who injures an opponent by elbowing shall be assessed at the discretion of the Referee a:

- ▶ **Major** penalty + **Automatic Game Misconduct** penalty (5'+GM)
- or
- ▶ **Match** penalty (MP)

527 - EXCESSIVE ROUGHNESS

Any player who commits an action not permitted by the rules that may cause or causes an injury to an opponent, to a team or game official shall be assessed a:

- ▶ **Match** penalty (MP)

The circumstances shall be reported to the:

- ▶ **Proper Authorities**

528 - FISTICUFFS OR ROUGHING

a) A player who intentionally takes off his glove/s in a fight or altercation shall be assessed a:

- ▶ **Misconduct** penalty (10')

b) A player who starts fisticuffs shall be assessed a:

- ▶ **Match** penalty (MP)

c) A player who, having been struck, retaliates with a blow or attempted blow, shall be assessed a:

- ▶ **Minor** penalty (2')

d) Any player or goalkeeper who is the first to intervene in an altercation already in progress, shall be assessed in addition to any other penalties incurred in the incident a:

- ▶ **Game Misconduct** penalty (GM)

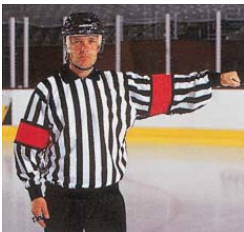

**ROUGHING SIGNAL
RULE 528**



FISTICUFFS

e) If a player, after he has been ordered by the Referee to stop, continues the altercation, attempts to continue, or resists a Linesman in the discharge of his duties, he shall be assessed, at the discretion of the referee, a:

- ▶ **Double Minor** penalty (2'+2')
- or
- ▶ **Major** penalty + **Automatic Game Misconduct** penalty (5'+GM)
- or
- ▶ **Match** penalty (MP)

f) A player or goalkeeper who is on or off the ice and is involved in an altercation or fisticuffs with a player, goalkeeper or team official off of the playing surface shall be assessed, at the discretion of the referee, a: **NEW**

- ▶ **Misconduct** penalty (10')
- or
- ▶ **Game Misconduct** penalty (GM)
- or
- ▶ **Match** penalty (MP)

g) A team official who is on or off the ice and is involved in an altercation or fisticuffs with a player, goalkeeper or team official on or off the playing surface shall be assessed, at the discretion of the Referee, a: **NEW**

- ▶ **Game Misconduct** penalty (GM)
- or
- ▶ **Match** penalty (MP)

h) If a player is deemed guilty of unnecessary roughness, he shall be assessed, at the discretion of the Referee, a:

- ▶ **Minor** penalty (2')
- or
- ▶ **Double Minor** penalty (2' + 2')
- or
- ▶ **Major** penalty + **Automatic Game Misconduct** penalty (5' + GM)

i) A player who grabs or holds the face mask or helmet or pulls the hair of an opponent shall be assessed, at the discretion of the Referee, a:

- ▶ **Minor** penalty (2')
- or
- ▶ **Major** penalty + **Automatic Game Misconduct** penalty (5' + GM)

j) A goalkeeper using his blocker glove to punch an opponent in the head, neck or face area shall be assessed a

- ▶ **Match** penalty

▶ Attempt to head-Butting shall include all cases when a head-butting gesture is made but no contact is made

529 - HEAD-BUTTING

A player who attempts to or deliberately head-butts an opponent shall be assessed a:

- ▶ **Match** penalty (MP)

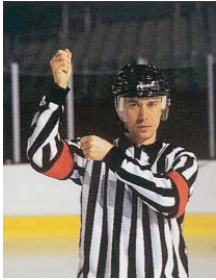

HIGH STICKING SIGNAL
RULE 530



HIGH STICKING

- ▶ Cradling the puck on the blade of the stick (like lacrosse) above the normal height of the shoulders shall be prohibited and a stoppage of play shall result.
- ▶ If this is done by a player on a Penalty Shot or a Game Winning Shot, the play will be immediately blown dead by the Referee and the play will be considered complete

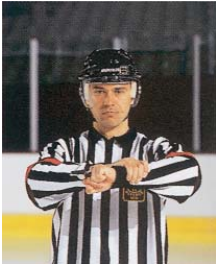

HOLDING SIGNAL
RULE 531



HOLDING

HOLDING THE STICK SIGNAL
RULE 532



(Two Stage Signal)

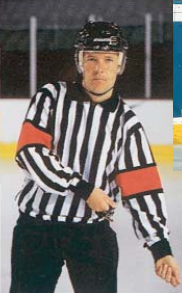

HOLDING THE STICK

530 - HIGH STICKING

- a) A player who carries or holds his stick or any part of it above the height of his shoulders that makes contact with an opponent shall be assessed, at the discretion of the Referee, a:
- ▶ **Minor** penalty (2')
 - or
 - ▶ **Major** penalty + **Automatic Game Misconduct** penalty (5'+GM)
 - or
 - ▶ **Match** penalty (MP)
- b) A player who carries or holds his stick or any part of it above the height of the shoulders that makes contact with an opponent and causes an injury with his stick or any part of it to an opponent shall be assessed at the discretion of the Referee a:
- ▶ **Major** penalty + **Automatic Game Misconduct** penalty (5'+GM)
 - or
 - ▶ **Match** penalty (MP)
- c) However, if the high sticking action that caused the injury was judged accidental, the offending player shall be assessed a:
- ▶ **Double Minor** penalty (2'+2')

531 - HOLDING AN OPPONENT

- A player who holds an opponent with his hands or stick or in any other way shall be assessed a:
- ▶ **Minor** penalty (2')

532 - HOLDING THE STICK

- A player who holds an opponent's stick with his hands or in any other way shall be assessed a:
- ▶ **Minor** penalty (2')

533 - HOOKING

- a) A player who impedes or seeks to impede the progress of an opponent by hooking him with his stick shall be assessed at the discretion of the Referee a:
- ▶ **Minor** penalty (2')
 - or
 - ▶ **Major** penalty + **Automatic Game Misconduct** penalty (5'+GM)
 - or
 - ▶ **Match** penalty (MP)



HOOKING SIGNAL RULE 533

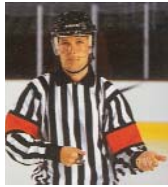

HOOKING

- ▶ 1. A **"Breakaway"** shall be defined as situation when a player is in full control of the puck and has no opposing player between himself and the opposing goalkeeper or goal, if the goalkeeper has been removed.
- ▶ 2. **"Control of the puck"** is the act of propelling the puck with the stick. If the puck is touched by another player or his equipment while it is being propelled and hits the goal or goes free, the player shall no be longer considered to be in control of the puck.
- ▶ 3. The referee shall not stop the play until the attacking team has lost possession of the puck.
- ▶ 4. The position of the puck shall be the determining factor. The puck shall be fully outside the defending blue line to award a Penalty Shot or a goal.
- ▶ 5. The intention of this rule is to restore a reasonable scoring opportunity, which shall have been lost by treason of a foul from behind.

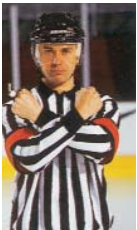

INTERFERENCE SIGNAL RULE 534



INTERFERENCE

- ▶ 1. This rule applies to any interference action, such as knocking a stick out of an opponents hands and preventing a player who lost his stick to regain possession.
- ▶ 2. The last player to touch the puck, other than a goalkeeper, shall be considered as in possession of the puck.
- ▶ 3. If an attacking player stands in the goal crease, without interfering with the goalkeeper, the Referee shall stop the play and the ensuing face-off shall take place at the nearest face-off spot in the neutral zone.

b) A player who injures an opponent by hooking shall be assessed at the discretion of the Referee:

- ▶ **Major penalty + Automatic Game Misconduct penalty** (5' +GM)
- or
- ▶ **Match penalty** (MP)

c) In a **"Breakaway Situation"**, when a player in control of the puck outside his own defending zone has no opponent to pass to other than the goalkeeper and he is hooked or otherwise fouled from behind, thus preventing a reasonable opportunity to score, the Referee shall award to the non-offending team a: **NEW**

- ▶ **Penalty Shot** (PS)

d) If, when the opposing goalkeeper has been removed from the ice, and the player in control of the puck outside of his own defending zone has no opponent to pass between him and the opposing goal is hooked or otherwise fouled from behind, thus preventing a reasonable opportunity to score, the Referee shall award to the non-offending team a: **NEW**

- ▶ **Goal**

534 - INTERFERENCE

a) A player who interferes or impedes the progress of an opponent who is not in possession of the puck shall be assessed a:

- ▶ **Minor penalty** (2')

b) A player on either the players bench or the penalty bench who, by means of his stick or his body, interferes with the movement of the puck of any opponent on the ice during the progress of the play, shall be assessed a:

- ▶ **Minor penalty** (2')

c) A player who, by means of his stick or his body, interferes with or impedes the progress of the goalkeeper while he is in his goal crease, shall be assessed a:

- ▶ **Minor penalty** (2')

d) If, when the goalkeeper has been removed from the ice, any member of his team, including a team official interferes by means of his stick or any other object or his body with the movement of the puck by an opposing player outside his own defending zone, the Referee shall award to the non-offending team a: **NEW**

- ▶ **Goal**

e) If an attacking player positions himself facing the opposing goalkeeper and engages in actions such as waving his arms or stick in front of the goalkeeper's face for the purpose of interfering and/or distracting the goalkeeper as opposed to positioning himself to try to make a play, regardless whether the attacking player is positioned inside or outside of the goal crease, the Referee shall assess a: **NEW**

- ▶ **Minor penalty** (2')

- ▶ Attempt to kick shall include all cases when a kicking gesture is made but no contact is made.

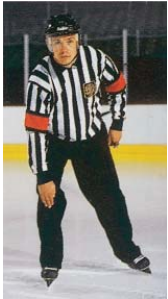

KNEEING SIGNAL
RULE 536



KNEEING

- ▶ 1. The referee should assess a slashing penalty to any player who swings his stick at an opponent without actually striking him, or makes a wild swing at the puck with the object of intimidating an opponent.
- ▶ 2. "Tapping the stick" of the puck carrier is not considered slashing if it is limited to hitting the stick for the sole purpose of taking the puck.



SLASHING

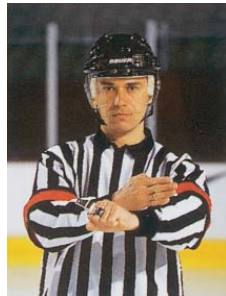

SLASHING SIGNAL
RULE 537

535 - KICKING

A player who kicks or attempts to kick another player, shall be assessed a:

- ▶ **Match penalty** (MP)

536 - KNEEING

a) A player who uses his knee to foul an opponent shall be assessed at the discretion of the Referee, a:

- ▶ **Minor penalty** (2')
- or
- ▶ **Major penalty + Automatic Game Misconduct penalty** (5'+GM)
- or
- ▶ **Match penalty** (MP)

b) A player who injures an opponent by kneeing shall be assessed at the discretion of the referee a:

- ▶ **Major penalty + Automatic Game Misconduct penalty** (5'+GM)
- or
- ▶ **Match penalty** (MP)

537 - SLASHING

a) A player who impedes or seeks to impede the progress of an opponent by slashing with his stick shall be assessed, at the discretion of the Referee, a:

- ▶ **Minor penalty** (2')
- or
- ▶ **Major penalty + Automatic Game Misconduct penalty** (5'+GM)
- or
- ▶ **Match penalty** (MP)

b) A player who injures an opponent by slashing shall be assessed at the discretion of the Referee a:

- ▶ **Major penalty + Automatic Game Misconduct penalty** (5'+GM)
- or
- ▶ **Match penalty** (MP)

c) A player who swings his stick at another player in the course of any altercation shall be assessed at the discretion of the Referee a:

- ▶ **Major penalty + Automatic Game Misconduct penalty** (5'+GM)
- or
- ▶ **Match penalty** (MP)

- ▶ 1. **“Attempt to spear”** shall include all cases when a spearing gesture is made but no contact is made.
- ▶ 2. **“Spearing”** is the action of stabbing an opponent with the point of the stick blade, whether or not the stick is being carried with one or both hands.

SPEARING SIGNAL
RULE 538

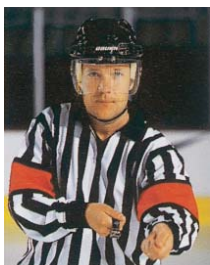

If, in the opinion of the Referee, a player who uses his stick in such a manner that he shall knock or hook away the puck away from an opponent first and while doing so the momentum of his stick causes his opponent to trip or fall, no penalty shall be assessed as the puck was played initially and not the puck carrying opponent

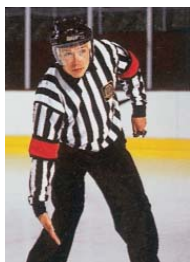

TRIPPING SIGNAL
RULE 539



TRIPPING

- ▶ 1. A **“Breakaway”** shall be defined as a situation where a player is in full control of the puck and has no opposing player between himself and the opposing goalkeeper or goal, if the goalkeeper has been removed.
- ▶ 2. **“Control of the puck”** is the act of propelling the puck with the stick. If the puck is touched by another player or his equipment while it is being propelled, or hits the goal or goes free, the player shall no be longer considered as being in control of the puck.
- ▶ 3. The referee shall not stop the play until the attacking team has lost possession of the puck.
- ▶ 4. The position of the puck shall be the determining factor. The puck shall be fully outside the defending blue line to award a Penalty Shot or a goal.
- ▶ 5. The intention of this rule is to restore a reasonable scoring opportunity, which has been lost by reason of a foul from behind.

538 - SPEARING

- a) A player who attempts to spear an opponent shall be assessed a:
 - ▶ **Double Minor penalty + Misconduct penalty** (2'+2'+10')
- b) A player who spears an opponent shall be assessed at the discretion of the Referee, a:
 - ▶ **Major penalty + Automatic Game Misconduct penalty** (5'+GM)
 - or
 - ▶ **Match penalty** (MP)
- c) A player who injures an opponent by spearing shall be assessed a:
 - ▶ **Match penalty** (MP)

539 - TRIPPING

- a) A player who shall place his stick, leg, foot, arm, hand or elbow in such a manner that it shall cause his opponent to trip or fall shall be assessed, at the discretion of the Referee, a:
 - ▶ **Minor penalty** (2')
 - or
 - ▶ **Major penalty + Automatic Game Misconduct penalty** (5'+GM)
 - or
 - ▶ **Match penalty** (MP)
- b) A player who injures an opponent by tripping shall be assessed at the discretion of the Referee a:
 - ▶ **Major penalty + Automatic Game Misconduct penalty** (5'+GM)
 - or
 - ▶ **Match penalty** (MP)
- c) In a **“Breakaway Situation”**, when a player, in **“Control of the Puck”** outside his own **NEW** defending zone with no opponent to pass to other than the goalkeeper, is tripped or otherwise fouled from behind, thus preventing a reasonable scoring opportunity, the Referee shall award to the non-offending team a:
 - ▶ **Penalty Shot** (PS)
- d) If, when the opposing goalkeeper has been removed from the ice, and the player in **NEW** **“Control of the Puck”** outside his own defending zone, has no opponent to pass between him and the opposing goal is tripped or otherwise fouled from behind, the Referee shall award to the non-offending team a:
 - ▶ **Goal**

- ▶ 1. An appropriate penalty for checking to the head shall be assessed if one of the following conditions listed below take place in the process of checking the opposing player:
 1. The player directs a check or blow with any part of his body to the head and neck area of the opposing player
 2. The player "drives" or "forces" the head of an opposing player into the protective glass or boards by using any part of his body listed in # 3 below.
 3. The player extends and directs his arm, elbow, forearm or shoulder to contact the head and neck area of the opposing player.
 4. The player by extending his body upward or outward in order to reach his opponent and using any part of the body listed in #3 to contact his opponent's head or neck area.
 5. The checking player jumping or leaving his skates from the ice in order to deliver a blow to the head or neck area of the opposing player
 6. A cross check action to the head and or neck area
 7. A goalkeeper who uses his blocker glove to punch an opponent in the head, neck or face area. BUT a Match penalty is to be assessed in this situation.

- ▶ 2. A player is responsible to keep his head up and be aware of his position and the possibility of being checked. To be checked is a normal part of the game and players should be prepared to protect themselves as approved by the rules.
- ▶ 3. The mere fact that a player may or may not be prepared to protect himself or may or may not be aware of an impending hit does not change the result that a hit to the head is to go un-penalized.
- ▶ 4. As a guideline, where the major force of the blow is initially to the body area and then "slides" up to the head area, this is not classified as "checking to the head".
- ▶ 5. A check delivered by a player on an opponent carrying the puck with his head down as he approaches the checking player, shall not be ruled as "checking to the head" if the checking player does not raise, extend or direct his arm, elbow, shoulder or any part of his body towards the head or neck area of the opponent.
- ▶ 6. If the checking player is maintaining his position in the normal manner as a part of the game while the opposing player is approaching him, his check will not be considered as "checking to the head" unless the points listed in #3 or #4 above apply.
- ▶ 7. A punch or blow to the head and neck area during altercations and fights shall not be classified as checking to the head but the penalty shall be assessed according to the Rule 528 - Fisticuffs or Roughing

540 – CHECKING TO THE HEAD AND NECK AREA.

- a) A player who directs a check or blow, with any part of his body or equipment to the head and neck area of an opposing player or "drives" or "forces" the head of an opposing player into the protective glass on boards, shall be assessed at the discretion of the Referee a:
- ▶ **Minor penalty + Automatic Misconduct penalty** (2'+10')
 - or
 - ▶ **Major penalty + Automatic Game Misconduct penalty** (5'+GM)
 - or
 - ▶ **Match Penalty** (MP)
- b) A player who injures an opponent as result of checking to the Head and Neck Area shall be assessed, a:
- ▶ **Match Penalty** (MP)
- c) This rule supersedes Rules 520, 522, 525, 526 and 537 with regard to all actions described under articles a) and b). **NEW**

541 - WOMEN BODY-CHECKING

In women's ice hockey, if a player makes a direct body-check, she shall be assessed, at the discretion of the Referee, a:

- ▶ **Minor penalty** (2')
- or
- ▶ **Major penalty + Automatic Game Misconduct penalty** (5'+GM)

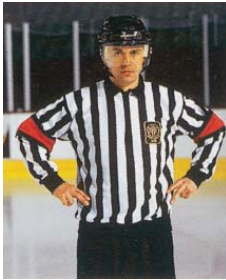

MISCONDUCT PENALTY SIGNAL
RULES 504, 550, 551

To enforce this rule, the Referee has, in many instances, the following options:

- ▶ **1. Bench Minor penalty** for violations occurring on or in the vicinity of the player's bench, but off of the playing surface and affecting non-playing personnel.
- ▶ **2. Misconduct penalty** for violations occurring on the playing surface or in the penalty bench and where the penalized player is readily identifiable.

OTHER PENALTIES

550 - ABUSE OF OFFICIAL AND UNSPORTSMANLIKE CONDUCT BY PLAYERS

a) If any player:

1. When penalized, does not go directly to the penalty bench or the dressing room.
2. While off the ice, uses obscene, profane or abusive language
3. While off the ice, interferes in any manner with any official
his team shall be assessed a:

▶ **Bench Minor** penalty (2')

b) A player who:

1. Challenges or disputes the ruling of any official during the game,
2. Shoots intentionally the puck out of reach of an official who is retrieving it
3. Enters or remains in the Referee crease while the Referee is reporting to any official.
he shall be assessed a:

▶ **Misconduct** penalty (10')

For any further dispute, he shall be assessed a:

▶ **Game Misconduct** penalty (GM)

c) If a player on the ice who:

1. Uses obscene, profane or abusive language on the ice or anywhere in the rink before, during or after the game except in the vicinity of the bench.
2. Bangs the boards with a stick or other object at any time.
3. Fails to go directly and immediately to the penalty bench following a fight or any altercation which he has been involved or causes any delay retrieving his equipment.
4. Persists to incite an opponent into incurring a penalty,
he shall be assessed a:

▶ **Misconduct** penalty (10')

d) If a player on the ice persists in any course of conduct for which he has been previously assessed a Misconduct penalty, he shall be assessed a:

▶ **Game Misconduct** penalty (GM)

e) A player who uses or makes any racial remark or ethnic slur shall be assessed a:

▶ **Game Misconduct** penalty (GM)

f) Any player who:

1. Intentionally touches with hands or stick, holds or pushes or checks with hands, stick or body, trips, slashes, hits in any manner or spits at a game official.
2. Makes a travesty of or interferes with or is detrimental to the conducting of the game
3. While on or off the ice or anywhere in the rink before, during or after the game makes any obscene gesture to any official or any person.
4. Spits at any person on the ice or anywhere in the rink.
he shall be assessed a:

▶ **Match** penalty (MP)

- ▶ The player's gloves and stick shall be delivered to him at the penalty bench by a teammate

g) If an identified player who is off the ice throws a stick or any other object on to the playing surface from the player's bench or from the penalty bench, he shall be assessed a: **NEW**

▶ **Minor penalty + Automatic Game Misconduct** penalty (2'+GM)

h) If an unidentified player who is off the ice throws a stick or any other object on to the playing surface from the player's bench or from the penalty bench, his team shall be assessed a: **NEW**

▶ **Bench Minor** penalty (2')

551 - ABUSE OF OFFICIALS AND UNSPORTSMANLIKE CONDUCT BY TEAM OFFICIALS

a) If any team official:

1. Uses obscene, profane or abusive language to any official or any person.
2. Interferes in any manner with any of the officials of the game.
3. Bangs the boards with a stick or other object at any time.

his team shall be assessed a:

▶ **Bench Minor** penalty (2')

b) If he persists, or if he is guilty of any type of misconduct he shall be assessed a:

▶ **Game Misconduct** penalty (GM)

c) A team official who uses or makes any racial remark or ethnic slur shall be assessed a:

▶ **Game Misconduct** penalty (GM)

d) If any team official:

1. Holds or strikes an official.
2. Makes a travesty of or is detrimental to the conducting of the game.
3. Makes any obscene gesture to any official or any person.
4. Spits at a game official.

he shall be assessed a:

▶ **Match** penalty (MP)

e) If an identified team official throws a stick or any other object on to the playing surface from his player's bench he shall be assessed a:

▶ **Game Misconduct** penalty (GM)

And his team a:

▶ **Bench Minor** penalty (2')

f) If an unidentified team official throws a stick or any other object onto the playing surface from his player's bench his team shall be assessed a:

▶ **Bench Minor** penalty (2')



KEEPING THE PUCK IN MOTION



GOAL FRAME DISPLACED

554 - DELAYING THE GAME

554a) - KEEPING THE PUCK IN MOTION

- a) The puck shall be kept in motion at all times. A team in possession of the puck in its own defending zone shall advance the puck towards the opposing goal except:
1. To carry the puck behind his goal once
 2. If it is prevented to do so by players of the opposing team
 3. If the team is short-handed.

- b) A player beyond his defending zone shall not pass or carry the puck backward into his defending zone for the purpose of delaying the game, except when his team is shorthanded.

For the first infraction, the referee shall assess a:

- ▶ **Warning** to the Captain of the offending team.

For the second infraction, during the same period, the offending player shall be assessed a:

- ▶ **Minor penalty** (2')
- c) Any player or goalkeeper who holds or plays the puck with his stick, skates or body along the boards in such a manner to cause a stoppage of play, unless he is actually checked by an opponent, shall be assessed a:
- ▶ **Minor penalty** (2')

554b) - DISPLACING THE GOAL FRAME

- a) A player or goalkeeper who deliberately displaces a goal frame from its normal position shall be assessed a:

- ▶ **Minor penalty** (2')

- b) If it happens during the last two minutes of the game, or at any time in overtime, by a defending player or goalkeeper in his defending zone the Referee shall award to the non-offending team a:

- ▶ **Penalty Shot** (PS)

- c) If a player or goalkeeper deliberately displaces a goal frame from its normal position when an opponent is in control of the puck with no opposition between him and the goalkeeper, and with a reasonable opportunity to score, the Referee shall award to the non-offending team a:

- ▶ **Penalty Shot** (PS)

- d) If, when a goalkeeper has been removed from the ice, a player of his team displaces the goal frame from its normal position when an opponent is in control of the puck with no opposition between him and the goal, the Referee shall award to the non-offending team a:

- ▶ **Goal**

- ▶ 1. The "**playing area**" in this rule means the surface surrounded by the boards and protective glass. The height of the playing area is infinity.
- ▶ 2. The words "**except where there is no glass**" refer to the space in front of the both players' benches of IIHF ice rinks standards.
- ▶ 3. The determining factor for assessing the penalty shall be the positioning of the puck at the moment the puck is shot, thrown or batted with the hands or stick by a player or goalkeeper.
- ▶ 4. No penalty shall be assessed if the puck is shot from the defending zone and hits the clock causing a stoppage of play.

- ▶ 1. This penalty shall be announced as a "Minor Penalty for the Delay of the Game - Violation of Adjustment of Equipment".

- ▶ 1. This penalty shall be announced as a "Minor Penalty for the Delay of the Game - Injured Player refusing to leave the Ice".

- ▶ 1. This penalty shall be announced as a "Bench Minor Penalty for the Delay of the Game - More Than One Change on the ice after Goal Scored".

- e) If at any time during the course of the penalty Shot (which begins when the Referee blows the whistle for the player to start the shot) the goalkeeper deliberately moves or dislodges the goal net, the Referee shall award to the non-offending team a:

▶ **Goal**

554 c) - SHOOTING OR THROWING THE PUCK OUTSIDE THE PLAYING AREA NEW

- a) When any player or goalkeeper, while in his defending zone, shoots, throws or bats the puck with his hand or stick directly, (non-deflected) out of the playing area, except where there is no glass, a minor penalty shall be assessed for delaying the game.
- b) When the puck is shot, thrown or batted with the hands or stick by a player or goalkeeper into the player's bench (or penalty bench if there is no protective glass), no penalty shall be assessed.
- c) When the puck is shot, thrown or batted with the hands or stick by a player or goalkeeper over the glass, behind the player's bench (or penalty bench if there is no protective glass) the penalty shall be assessed.
- d) A **Minor penalty** for delay of game shall be imposed on any player or goalkeeper who deliberately shoots or bats the puck outside the playing area during the play or after a stoppage of play unless covered by this rule.

554 d) - ADJUSTMENT OF EQUIPMENT

- a) Play shall not be stopped nor the game delayed by reason of repair or adjustments to player's equipment and uniform, and the player requiring such adjustments shall retire from the ice
- b) Play shall not be stopped nor the game delayed by reason of repair or adjustments to goalkeeper's equipment and uniform, and the goalkeeper requiring such adjustments shall retire from the ice and the substitute goalkeeper shall take his place immediately.
- c) For any infraction to this rule the player or goalkeeper shall be assessed a:
 - ▶ **Minor penalty** (2')

554 e) - INJURED PLAYER REFUSING TO LEAVE THE ICE

An injured player who refuses to leave the ice shall be assessed a:

▶ **Minor penalty** (2')

554 f) - MORE THAN ONE CHANGE AFTER GOAL SCORED

If a team after scoring a goal makes more than one change of players on the ice it shall be assessed a:

▶ **Bench Minor penalty** (2')

- ▶ 1. This penalty shall be announced as a "Bench Minor Penalty for the Delay of the Game - Face - Off Violation".

- ▶ 1. This penalty shall be announced as a "Bench Minor Penalty for the Delay of the Game - Line Up Violation".

- ▶ 1. The guilty player shall not be allowed to participate in the game until the illegal equipment has been corrected or removed.
- ▶ 2. Penalties assessed under this rule shall be announced as "Delay of the Game - Illegal or Dangerous Equipment".

554 g) - VIOLATION OF FACE-OFF PROCEDURES

- a) When a player has been removed from the face-off by an official and another player of the same team delays taking up his proper position after a "Warning", his team shall be assessed a:
 - ▶ **Bench Minor** penalty (2')
- b) When a player not taking the face-off enters the face-off circle before the puck is dropped, the player on his team taking the face-off shall be removed and replaced. For the second violation during the same face-off, the offending team shall be assessed a:
 - ▶ **Bench Minor** penalty (2')

554 h) - LATE LINE-UP

- If a team after the end of an intermission does not line up on the ice surface a required number of players to start a period including overtime, the team shall be assessed a:
- ▶ **Bench Minor** penalty (2')

555 - ILLEGAL OR DANGEROUS EQUIPMENT

- a) A player or goalkeeper who:
 1. Wears his equipment or visor in a way that may cause an injury to an opponent.
 2. Wears any non approved equipment.
 3. Uses or wears illegal or dangerous skates, sticks or equipment.
 4. Does not wear his equipment, except gloves, head protection and goalkeeper's leg guards, entirely under his uniform.
 5. A player who wears a glove in play from which all or part of the palm has been removed or cut to permit the use of bare hand.

Shall be ruled off the ice and a "Warning" shall be issued to his team.
- b) The referee can request that a player or goalkeeper remove any personal accessories should, in the discretion of the Referee, the personnel accessory worn during a game be regarded as dangerous for this player and other participants. If these personnel accessory are difficult to remove then the player or goalkeeper should tape the personnel accessory or put the item safety under the jersey in such way that they no longer be dangerous. In this case the player or goalkeeper shall be ruled off the ice and a warning shall be issued to his team.
- c) For a second violation by any player or goalkeeper of the same team for any offence of this rule, the Referee shall assess to the offending player or goalkeeper a:
 - ▶ **Misconduct** penalty (10')
- d) If a player or goalkeeper refuses to surrender or destroys his stick or any part of his equipment for measurement when requested by the Referee, this equipment shall be regarded as illegal and the player or goalkeeper shall be assessed a:
 - ▶ **Minor** penalty + **Misconduct** penalty (2'+10')

- ▶ 1. A "broken stick" is one which, in the opinion of the Referee, is unfit for normal play.
- ▶ 2. A player without a stick may participate in the game.
- ▶ 3. Penalties assessed under this rule shall be announced as "Minor Penalty for Illegal Substitution of the Stick".

- ▶ A player who drops on the ice to block a shot should not be penalized if the puck is shot under him or becomes lodged in his clothing or equipment, but any use of the hands to make the puck unplayable shall be penalized.

e) If a team has requested the measurement of any equipment of the opposing team and if the complaint is sustained the offending player shall be assessed a:

- ▶ **Minor** penalty (2')

f) If a team has requested the measurement of any equipment of the opposing team and if the complaint is not sustained the team shall be assessed a

- ▶ **Bench Minor** penalty (2')

g) A player on the ice whose helmet comes off during play, who does not return to his bench immediately but continues to play shall be assessed a: **NEW**

- ▶ **Minor** penalty (2')

556 - BROKEN STICK

a) A player or goalkeeper whose stick is broken shall not receive a stick thrown onto the ice, but may receive a stick from a teammate on the ice at the time without proceeding to his player bench. **NEW**

b) If a player or goalkeeper whose stick is broken, does not immediately drop the broken portions and continue to play, he shall be assessed a: **NEW**

- ▶ **Minor** penalty (2')

c) If the goalkeeper goes to the player bench during a stoppage of play to replace his stick, and then returns back to resume play, he shall be assessed a:

- ▶ **Minor** penalty (2')

However, if the goalkeeper is changed for the substitute goalkeeper, no penalty shall be assessed.

d) The goalkeeper is allowed to go to the player bench and change his stick when the play is in progress.

e) If a player participates in the play while taking a replacement stick to a player or goalkeeper, he shall be assessed a:

- ▶ **Minor** penalty (2')

f) If a player, whose stick is broken receives a stick during play from a team mate in the penalty bench, the receiving player shall be assessed: **NEW**

- ▶ **Minor** penalty (2')

557 - FALLING ON THE PUCK BY A PLAYER

a) If a player, other than the goalkeeper, who deliberately falls on, holds or gathers the puck into his body, he shall be assessed a:

- ▶ **Minor** penalty (2')

b) If a defending player, other than the goalkeeper, deliberately falls on, holds or gathers the puck into his body when the puck is in the goal crease of his team, the Referee shall award to the non-offending team a:

- ▶ **Penalty Shot** (PS)

FALLING ON THE PUCK BY A GOALKEEPER

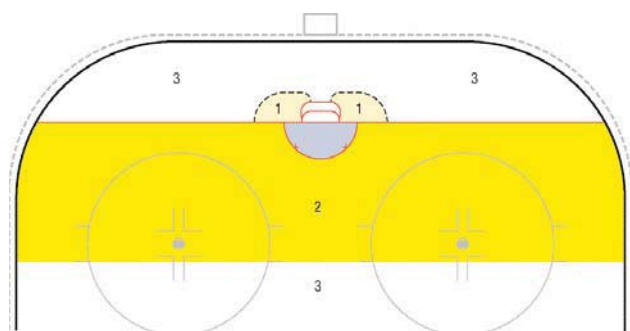

- 1 Goalkeeper is allowed to freeze the puck only when the goalkeeper's body remains at least partially in the goal crease.
- 2 Goalkeeper is allowed to freeze the puck only when he is pressured.
- 3 Goalkeeper is **not** allowed to freeze the puck.

- ▶ **No Goal** shall be awarded if the puck was batted by an attacking player with the hand, even if it deflects off any player or goalkeeper or the sticks of the players or goalkeeper of either team or official.

- c) If the opposing goalkeeper has been removed from the ice and a player deliberately falls on, holds or gathers the puck into his body when the puck is in the goal crease of his team, the Referee shall award to the non-offending team a:

▶ **Goal**

558 - FALLING ON THE PUCK BY A GOALKEEPER

- a) If a goalkeeper, whose body is entirely outside the goal crease, and when the puck is behind the goal line or beyond the two lines on each side of the face-off circles, deliberately falls on or gathers the puck into his body, or holds or places the puck against any part of the goal or the boards, he shall be assessed a:

▶ **Minor penalty** (2')

- b) If the goalkeeper falls or gathers the puck into his body in the area between the goal line and the hash marks (as shown on the diagram) unless he is being pressed, he shall be assessed a:

▶ **Minor penalty** (2')

559 - HANDLING THE PUCK WITH THE HANDS BY A PLAYER

- a) A player shall be permitted to stop or bat a puck in the air with his open hand or push it along the ice with his hand and the play shall not be stopped unless in the opinion of referee he has deliberately directed the puck to a teammate or has allowed his team to gain an advantage in any zone other than the defending zone in which case the play shall be stopped and a face off conducted (See Rule 490). Play will not be stopped for any hand pass by players in their own defending zone. **NEW**

- b) A player shall be permitted to catch the puck out of the air but must immediately place it or knock it down to the ice. If he catches it and skate with it either to avoid a check or to gain a territorial advantage over his opponent he shall be assessed a: **NEW**

▶ **Minor penalty** (2')
for "closing his hand on the puck"

- c) Any player, except the goalkeeper, who picks up the puck from the ice with hands shall be assessed a:

▶ **Minor penalty** (2')

- d) If any defending player, except the goalkeeper, picks up the puck with his hands from the ice in his goal crease, the Referee shall award to the non-offending team a:

▶ **Penalty Shot** (PS)

- e) If the goalkeeper is not on the ice as in d) above, the Referee shall award to the non-offending team a:

▶ **Goal**

- ▶ The object of this rule is to keep the puck in play continuously and any action by the goalkeeper which causes an unnecessary stoppage of play shall be penalized.

- ▶ 1. If a player shall illegally enter the game from his own player's bench or from the penalty bench by his own error or the error of the Penalty Bench Attendant, any goal scored by his own team shall be disallowed, while he is illegally on the ice, but all penalties imposed to both team shall be served.
- ▶ 2. If the player leaves the penalty bench because of an error of the Penalty Bench Attendant, he shall not be penalized but shall serve the remaining amount of time of his penalty when he re-entered the game.
- ▶ 3. The Penalty Bench Attendant shall note the time and advise the Referee at the first stoppage of play.
- ▶ 4. Substitutions made prior to the altercation shall be permitted provided the players so substituting do not enter the altercation.
- ▶ 5. If players of both teams leave their respective benches at the same time, the first identifiable player of each team shall be penalized under this rule.
- ▶ 6. For the purpose of determining which player was the first to leave his player's bench, the Referee shall consult with the Linesmen or off-ice officials.
- ▶ 7. A maximum of five Misconduct and/or Game Misconduct penalties per team can be assessed under this rule.

560 - HANDLING THE PUCK WITH HANDS BY A GOALKEEPER

- a) Unless he is being pressured a goalkeeper who holds the puck more than three seconds shall be assessed a:
 - ▶ **Minor** penalty (2')
- b) If a goalkeeper throws the puck forward and the puck is first played by a team-mate, the Referee will immediately blow the whistle to stop the play and an end zone face-off will be held **NEW**
- c) A goalkeeper who deliberately drops the puck into his pads shall be assessed a:
 - ▶ **Minor** penalty (2')

561 - INTERFERENCE WITH SPECTATORS

A player who physically interferes with a spectator shall be assessed, at the discretion of the Referee, a:

- ▶ **Match** penalty (MP)

562 - PLAYERS LEAVING THE PENALTY OR PLAYERS BENCH

- a) Except at the end of each period or for entering the game legally, no player or goalkeeper may, at any time, enter the ice surface from the players bench or the penalty bench **NEW**
- b) Except at the end of a period, a penalised player who leaves the penalty bench and enters the ice surface before his penalty time has expired shall be assessed a:
 - ▶ **Minor** penalty (2')
- c) Any player who, having entered the penalty bench, leaves the penalty bench prior to the expiration of his penalty for the purpose of challenging an official's ruling, shall be assessed a:
 - ▶ **Minor** penalty + **Game Misconduct** penalty (2'+GM)
- d) The first player to leave the players or penalty bench during an altercation shall be assessed a:
 - ▶ **Double Minor** penalty + **Automatic Game Misconduct** penalty (2'+ 2'+GM)
- e) Any other player(s) who leave the players bench during an altercation shall be assessed a:
 - ▶ **Misconduct** penalty (10')
- f) Any other player(s) who leave the penalty bench during an altercation shall be assessed a:
 - ▶ **Minor** penalty + **Misconduct** penalty (2'+10')

This will be served at the expiration of his previous penalty.

- ▶ Where an injury has occurred to a player and there is a stoppage of play, a team doctor (or designate) may go onto the ice to attend to the injured player without waiting for the Referee to wave him onto the ice

g) If a player or goalkeeper illegally enters the game and interferes with a player of the opposing team possession of the puck, who has no opponent between him and the goalkeeper, the Referee shall award to the non-offending team a:

▶ **Penalty Shot** (PS)

h) If, when the opposing goalkeeper has been removed from the ice, a player illegally enters the game and interferes with a player of the opposing team in possession of the puck, the Referee shall award to the non-offending team a:

▶ **Goal**

565 - TEAM OFFICIALS LEAVING THE PLAYERS BENCH

Any team official who goes on the ice during any period without the permission of the Referee shall be assessed a:

▶ **Game Misconduct** penalty (GM)

566 - REFUSING TO START PLAY - TEAM ON THE ICE

a) If, when both teams are on the ice and one team refuses to play for any reason when ordered to do so by the Referee, the Referee shall warn the Captain and allow to the team so refusing **30 seconds** to begin the game or resume play.

b) If at the end of that time the team still refuse to play, the Referee shall assess a:

▶ **Bench Minor** penalty (2')

c) If there be a recurrence of the same incident, the Referee will declare the game forfeited to the non-offending team and the case shall be reported to the **Proper Authorities for further actions**.

567 - REFUSING TO START PLAY - TEAM NOT ON THE ICE

a) If a team, which is not on the ice, fails to go on the ice to start playing when ordered by the Referee through the Captain, Manager or Coach, the Referee shall allow to the refusing team **two minutes**.

b) If the team resumes play within these two minutes, it shall be assessed a:

▶ **Bench Minor** penalty (2')

c) If, at the end of that time the team still fails to go on the ice, the Referee shall declare the game forfeited to the non-offending team and the case shall be reported by the Referee to the **Proper Authorities** immediately following the game for further actions.

568 - THROWING A STICK OR ANY OBJECT OUT OF THE PLAYING AREA

Any player or goalkeeper who throws a stick, part of it, or any other object out of the playing area shall be assessed a:

▶ **Game Misconduct** penalty (GM)

- ▶ When a player or goalkeeper discards the broken portion of a stick by tossing it to the side of the rink (and not over the boards) in such a way not to interfere with play or opposing player, no penalty will be imposed for so doing.
- ▶ The position of the puck or puck carrier at the moment when a stick or any part of it or any object is thrown or shoots or directed (with any part of body) by the opposing player or team official in the direction of the puck or puck carrier is the determinate factor to assess a **Minor Penalty** or a **Bench Minor penalty** to a Team Official or award a **Penalty shot**. When the goalkeeper has been removed from the ice refer to item e) of this rule.

- ▶ The **position of the puck** shall be the determining factor in this instance. The puck must be fully outside of the defending zone blue line in order to award a **Penalty Shot** or a **goal**.

569 - THROWING A STICK OR ANY OBJECT WITHIN THE PLAYING AREA

- a) Any player or goalkeeper on the ice or on the bench or team official, who shoots or throws a stick or any part of it or any object or who directs (with any part of his body) a stick or any part of it, or any object in the direction of the puck or puck carrier in his attacking zone or in the neutral zone shall be assessed a:
 - ▶ **Minor penalty** (2')
 - or
 - ▶ **Bench Minor penalty** (2') **NEW**
- b) If any player, goalkeeper or team official commits any of the actions described in section a) of this rule in his defending zone, the Referee shall award to the non-offending team a:
 - ▶ **Penalty Shot** (PS)
- c) If the goalkeeper intentionally leaves his stick or any part of it or any object in front of his goal, and if the puck hits such objects while the goalkeeper is on or off the ice, the Referee shall award to the non-offending team a:
 - ▶ **Goal**
- d) If a stick or any part of it or any object is thrown or shot or directed (with any part of his body) away by a player or goalkeeper on the ice and in no way interferes with the play, no penalty should be assessed to the player or goalkeeper.
- e) When the actions described in section a) of this rule, are committed against a player in control of the puck in any zone when the opposing goalkeeper has been removed from the ice, the Referee shall award to the non-offending team a:
 - ▶ **Goal** **NEW**

570 - THROWING A STICK OR ANY OBJECT ON A BREAKAWAY SITUATION

- a) When a player in control of the puck outside his own defending zone, and having no opponent to pass to other than the goalkeeper and any member of the opposing team including team officials, throw or shoot a stick or any part of it or any object or who directs (with any part of his body) a stick or part of it or any object in the direction of the puck or puck carrier, the Referee shall award to the non-offending team a:
 - ▶ **Penalty Shot** (PS)
- b) When the actions described in section a) of this rule are committed against a player in control of the puck outside his own Defending zone when the goalkeeper has been removed from the ice, the Referee shall award to the non-offending team a:
 - ▶ **Goal**

571 - PREVENTION OF INFECTIONS BY BLOOD

- a) A player bleeding or covered by blood of any player shall be considered as an injured player and shall leave the ice for treatment and/or cleaning. If he does not comply with this regulation he shall be assessed a:
 - ▶ **Minor penalty** (2')



**TOO MANY PLAYERS
ON THE ICE SIGNAL
RULE 573**

- ▶ Penalties assessed under this rule shall be announced as "Bench Minor Penalty for delay of the game - violation of change of players procedure."



DIVING

- b) Such player shall be permitted to return to the ice surface provided that:
 1. The cut is completely closed sealed with appropriate bandages.
 2. Any blood is removed from the player and his equipment and uniform are replaced or properly cleaned.
- c) If the ice surface, ice rink facilities or any objects are stained with blood, the Referee shall ensure that the bloodstains are removed by rink personnel after the first stoppage of play.

NEW

572 - CAPTAIN AND ALTERNATE CAPTAIN COMPLAINT

If the Captain or Alternate Captain comes to complain about the penalty, whether he was on the ice or he comes from the player's bench he shall be assessed a:

- ▶ **Misconduct** penalty (10')

573 - TOO MANY PLAYERS ON THE ICE

a) If, at any time during play a team has more than the number of players on the ice to which they are entitled, the team shall be assessed a:

- ▶ **Bench Minor** penalty (2')

b) If, in the last two minutes of the game and at any time in overtime a deliberate illegal substitution (too many players on the ice) is made, the Referee shall award to the non-offending team a:

- ▶ **Penalty Shot** (PS)

575 - INFRINGEMENT OF CHANGE OF PLAYERS PROCEDURE

a) Where a team attempts to make a player(s) change after its allotted period of time, the Referee shall send the player(s) back to the bench and issue a **warning** to the team.

b) Any further infraction(s) of this procedure at any time during the course of the game shall be assessed to the offending team a:

- ▶ **Bench Minor** penalty (2')

576 - DIVING

Any player who, at the discretion of the Referee, blatantly embellishes a fall, a reaction or fakes an injury in attempt to draw a penalty by his action, shall be assessed a:

- ▶ **Minor** penalty (2')

590 - PENALTIES FOR GOALKEEPERS

The procedures for goalkeeper penalties are outlined in Rule 511. Specific penalties for goalkeepers are outlined in the following rules:

- 509 Penalty Shot Procedure
- 528j Fisticuffs or Roughing **NEW**
- 554c Shooting or Throwing the Puck Outside the Playing Area
- 556 Broken Stick
- 558 Falling on the Puck
- 560 Handling the Puck with Hands
- 568 to 570 Throwing a Stick or Any Object

▶ The position of the goalkeeper's skates shall be the determining factor in this instance.

- ▶ 1. All calls concerning this rule shall be based strictly on the judgement of the referee.
- ▶ 2. "**Contact**", whether incidental or otherwise, between a goalkeeper and an attacking player may be with a stick or any part of the body.

591 - GOALKEEPER BEYOND THE CENTER RED LINE

If a goalkeeper participates in the play in any manner when he is beyond the center red line, he shall be assessed a:

▶ **Minor** penalty (2')

592 - GOALKEEPER GOING TO THE PLAYERS BENCH DURING STOPPAGE OF PLAY

If a goalkeeper goes to the players bench during a stoppage of play, except to be replaced or during a time out, his team shall be assessed a:

▶ **Bench Minor** penalty (2') **NEW**

593 - GOALKEEPER LEAVING HIS CREASE DURING AN ALTERCATION

If a goalkeeper leaves the immediate vicinity of his crease during an altercation he shall be assessed a:

▶ **Minor** penalty (2')

594 - GOALKEEPER DROPPING THE PUCK ON THE GOAL NETTING

If a goalkeeper drops the puck on the goal netting to cause a stoppage of play, he shall be assessed a:

▶ **Minor** penalty (2')

595 - PROTECTION OF GOALKEEPERS

- a) In all cases in which an attacking player initiates any contact with the goalkeeper, other than incidental contact, when the goalkeeper is inside the goal crease and whether or not a goal is scored, the attacking player shall be assessed the appropriate penalty.
- b) A goalkeeper is not "fair game" just because he is outside the goal crease. The penalty shall be assessed in every case where an attacking player makes unnecessary contact with the goalkeeper (See Rule 522). Incidental contact shall be permitted when the goalkeeper is in the act of playing the puck outside his goal crease provided the attacking player has made a reasonable effort to avoid such unnecessary contact.
- c) If an attacking player has been pushed, shoved or fouled by the defending player so as to cause him to come into contact with the goalkeeper, such contact shall not be deemed to be contact initiated by the attacking player according to this rule, provided the attacking player has made a reasonable effort to avoid such contact with the goalkeeper. **NEW**
- d) Where a goalkeeper has played the puck outside his goal crease and is then prevented from returning to his crease due to the actions of an attacking player other than incidental, such player shall be penalised for interference. **NEW**
- e) A goalkeeper shall be penalised if by his actions outside of his crease he interferes with an attacking player who is attempting to play puck or an opponent. **NEW**
- f) However, where an attacking player stands in the goal crease, play shall be stopped and a face-off shall take place at the nearest face-off spot in the neutral zone. **NEW**

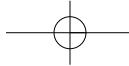

- ▶ 1. The game clock in the arena is the timing device, which is critical for these procedures.
- ▶ 2. During the warm-up each team shall confine their activities to their own half of the rink.
- ▶ 3. Music may be played during the warm-up.
- ▶ 4. In IIHF championships, the stand-by Referee shall supervise the warm-up procedures.

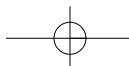

ANNEX 1 - ADVERTISING REGULATIONS

Advertising and venue identification may be placed on the ice, the boards, protective glass, nets, goals or any other surface in and around the players benches, penalty benches, Goal Judge areas and off-ice officials area, on the players uniforms and/or equipment, provided the specifications are provided to and written permission is given by:

1. The International Ice Hockey Federation with regards to IIHF championships.
2. The National Associations with regards to all games, both national and international, played within their territory.

ANNEX 2 - COUNTDOWN AND WARM-UP PROCEDURES

The following countdown procedure shall be followed prior to all IIHF ice hockey competitions (Subject can be changed for different IIHF Championships):

- | Time | |
|-------------|---|
| - 90:00 | Team Composition Forms delivered to the competing team. |
| - 60:00 | 20 minute countdown to the pre-game warm-up begins on the Game Clock. Teams submit their completed Team Composition Form to the Scorekeeper. Media centre receives a copy of the preliminary team line-ups. Game officials warm-up. |
| - 40:00 | 20 minute pre-game warm-up countdown on the clock begins. Game officials depart the ice surface. Both teams are on the ice for their pre-game warm-up. Warm-up music played in the arena for 20 minutes. |
| - 20:00 | Siren announces the end of warm-up. Teams depart the ice surface. Ice is re-surfaced. Countdown to actual game time begins on the Game Clock. Teams indicate their starting line-ups for the start of the game plus Captains and Assistant Captains on the Official Game Sheet. |
| - 10:00 | Teams receive a photocopy of the Official Game Sheet. Referee and Linesmen receive a photocopy of the Official Game Sheet. Doping Control receives a copy of the Official Game Sheet. Announcer announces the entire roster for both teams. |
| - 07:00 | Referee and Linesmen are notified that one minute remains until they need to proceed to the ice. |

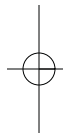

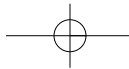

ANNOUNCEMENTS:

(See also IIHF Public Announcer Handbook and IIHF Off Ice Official Handbook).

GOALS AND ASSISTS:

"GOAL FOR TEAM... (Name of the team), SCORED BY NUMBER..., (Name), ASSISTED BY NUMBER..., (Name) AND NUMBER..., (Name). TIME..."

PENALTIES:

"TEAM... (Name of the team), NUMBER..., (NAME) 2 MINUTES PENALTY FOR... (PENALTY REASON). TIME..."

- ▶ 1. The penalty of the visiting team shall be announced first.
- ▶ 2. In a case where the penalized player cannot go to the penalty bench, or in case of goalkeeper penalty:

"THE PENALTY IS SERVED BY NUMBER...(NAME)".

END OF PENALTIES:

End of penalty for Team A (if other penalties are being served that make this team shorthanded):

"TEAM (NAME) IS PLAYING AT FULL STRENGTH" or, BOTH TEAMS ARE PLAYING AT FULL STRENGTH" (if no penalties remain for either team).

REVIEW BY VIDEO GOAL JUDGE:

"PLAY IS BEING REVIEWED".

In case goal is given: Announcement for "Goal Scored"

In case no goal is given: "NO GOAL HAS BEEN SCORED".

TIME OUT:

"TIME OUT FOR TEAM (NAME OF THE TEAM)

"TIME OUT IS OVER".

TIME REMAINING IN PERIOD/GAME:

At 01:00 1st Period: "ONE MINUTE LEFT IN THE FIRST PERIOD".

At 01:00 2nd Period: "ONE MINUTE LEFT IN THE SECOND PERIOD".

At 02:00 3rd Period: "TWO MINUTES LEFT IN THE THIRD PERIOD".

- 06:00 Teams are advised that they have one minute remaining until they need to proceed to the ice.
Referee and Linesmen leave their dressing room and go immediately to the ice.

- 05:00 Teams leave their dressing rooms and go directly to the ice.
Referee and Linesmen enter the ice.
International TV signal starts (Opening animation)

- 04:00 Teams enter the ice surface.

- 03:15 The Referee and Linesmen are standing in the Referee's Crease.

- 02:50 Official Announcer introduces the Referee and Linesmen.

- 02:30 Both teams line-up on their respective blue lines.

- 02:00 Team Captains greet the Referee and Linesmen in the Referee's Crease.

- 01:00 Teams leave the ice to the players' benches.
Starting players remain on the ice.

- 00:15 Referee calls the teams to center ice for the opening face-off.

- 00:00 Opening face-off.

ANNEX 3 - OFFICIAL ANNOUNCEMENTS

A3.1 - COMPULSORY ANNOUNCEMENTS

The following announcements are compulsory for the information of players, Coaches Referees and spectators:

1. Goals and Assists
2. Penalties
3. End of Penalties
4. Play Reviewed by the Video Goal Judge
5. Time-out
6. Time Remaining in Periods/Game

A3.2 - PUBLIC INFORMATION

1. Offside
2. Icing

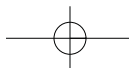

ANNEX 4 - DUTIES OF THE OFFICIALS

A4.1 - INCAPACITATED REFEREE OR LINESMAN - BEFORE THE GAME

If, for any reason, the appointed Referees or Linesmen are prevented from appearing, the team leaders shall agree on a replacement Referee and/or Linesman.

If they are unable to agree, the **Proper Authorities** shall appoint the officials.

A4.2 - INCAPACITATED REFEREE OR LINESMAN - DURING THE GAME

- a) If a **Referee** leaves the ice or is injured, the Linesman or other Referee shall stop the play, unless one team has a scoring opportunity.
- b) If the Referee is unable to continue to officiate, one of the Linesmen shall perform the Referee's duties. He shall be selected by the Referee Supervisor, the Referee or, if necessary, by the **team leaders**.
- c) If a **Linesman or the other Referee** is unable to officiate, the Referee shall have the power to appoint a replacement if he deems it necessary.
- d) If the appointed official reappears during the progress of the game, he shall replace the temporary official at once.

A4.3 - THREE MAN SYSTEM

The Referee and Linesmen shall remain on the ice at the conclusion of each period and at the end of the game until all of the players have left the ice and are proceeding to their dressing rooms.

A4.4 - THREE MAN SYSTEM - REFEREE DUTIES BEFORE THE GAME

The Referee shall have **general supervision of the game**, full control of game officials and players, and his decision shall be final in case of any dispute.

Before starting the game the Referee shall assure that the appointed officials are in their respective places and satisfy himself that the timing and signalling equipment are in order. He shall order the teams on the ice at the appointed time for the beginning of each period.

A4.5 - THREE MAN SYSTEM - REFEREE DUTIES DURING THE GAME

- a) The Referee shall impose and report to the Scorekeeper such **penalties** as are prescribed by the playing rules.
He shall allow the goals scored.
- b) The Referee may consult with the Linesmen, Goal Judge and Video Goal Judge, if available, in matters of disputed goals before making his decision, which shall be final.
- c) He shall report to the Scorekeeper the **number of the goal scorer** and any player(s) entitled to **assists**.
 - ▶ In top category IIHF Championships and the Olympic Winter Games, assists shall be awarded by the Scorekeeper.

- d) At the first stoppage of play he shall cause to be announced over the public address system the reason for not allowing a goal.
- e) He shall measure any equipment at his own discretion or if requested by the Captain of either team (Rule 260)
- f) He shall order the teams on the ice at the appointed time for the beginning of any period.
- g) He shall face-off the puck at the beginning of each period and after a goal has been scored.

A4.6 - THREE MAN SYSTEM, REFEREE DUTIES AFTER THE GAME

- a) The Referee shall secure the Official Game Sheet from the Official Scorer immediately following the game. He shall verify and sign the sheet and return it to the Official Scorer.
- b) The Referee shall report on the official game sheet immediately following the game giving full details to the Proper Authorities for all:
 1. **Game Misconduct** penalties
 2. **Match** penalties
 3. **Report** to the Proper Authorities any incident that happens before, during and after the game.

A4.7 - LINESMEN DUTIES

- a) The Linesmen shall determine and stop the play by blowing the whistle for any infraction of the rules concerning:
 1. Offside
 2. Icing
 3. Puck out of bounds, unplayable or interfered by an ineligible person
 4. Goal displaced from its normal position
 5. Encroachments occurring during a face-off
 6. Premature substitution of the goalkeeper
 7. Interference by spectators
 8. Injured players
 9. Pass with the hand from a player to a teammate
 10. High sticking the puck
- b) The linesman shall blow the whistle in case of a hand pass or high sticking the puck if it is obvious that the Referee did not observe the infraction.
- c) The Linesman shall only blow the whistle and report to the Referee penalties concerning:
 1. Too many players on the ice.
 2. Sticks or anything thrown on the ice from the vicinity of the player or penalty benches.
- d) The Linesman shall report to the referee when requested to do so by the Referee and give his version of any incident that may have taken place during the playing of the game.

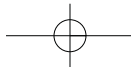

- e) He shall immediately give his version of the circumstances with respect to deliberately displacing the goal net from its normal position.
- f) He shall immediately give his version in case of:
1. **Bench Minor** penalties
 2. **Major** penalties
 3. **Misconduct** penalties
 4. **Game Misconduct** penalties
 5. **Match** penalties
- g) The Linesmen shall **conduct the face-offs at all times**, except at the start of each period and after a goal has been scored.

A4.8 - TWO MAN SYSTEM

The referees shall have general supervision of the game, full control of game officials and players, and their decision shall be final in case of any dispute.

A4.9 - TWO OFFICIAL SYSTEM - REFEREES' DUTIES BEFORE THE GAME

Before starting the game the referees shall ensure that the appointed officials are in their respective places and satisfy themselves that the timing and signalling equipment are in order. They shall order the teams on the ice at the appointed time for the beginning of each period.

A4.10 - TWO MAN SYSTEM - REFEREES' DUTIES DURING THE GAME

The Referees shall **impose and report** to the Scorekeeper such **penalties** as described by the playing rules for infractions thereof.

They shall **stop play for any other infractions to the rules**.

They shall **allow the goals scored**.

They shall **report** to the Scorekeeper the **name or number of the goal scorer** and any player(s) entitled to an **assist**.

They shall cause to be announced over the public address system the reason for not allowing a goal.

They shall measure any equipment at their own discretion or if requested by the Captain of either team (Rule 260).

They shall order the teams on the ice at the appointed time for the beginning of any period.

They shall **face-off the puck** at any stoppage of play.

A4.11 - TWO MAN SYSTEM - REFEREE'S DUTIES AFTER THE GAME

The referees shall remain on the ice at the conclusion of each period until all of the players have left the ice and are proceeding to their dressing rooms.

Immediately following the game, they shall secure the Official Game Sheet from the Official Scorer, verify and sign the report and return it back to the Official Scorer.

Immediately following the game, they shall report on the Official Game Sheet and provide full details to the Proper Authorities on all:

1. **Game Misconduct** penalties
2. **Match** penalties
3. **Report** to the Proper Authorities any incident that happens before, during and after the game.

A4.20 OFF-ICE OFFICIALS

A4.21 - SCOREKEEPER'S DUTIES BEFORE THE GAME

The Scorekeeper shall obtain from the Manager of Coach of both teams the list of all eligible players.

He shall complete the Official Game Sheet with the following information:

1. Name, position and number of each player, indicating the Captain and Alternate Captain by placing the letters "C" and "A" in front of their names.
2. All data concerning the game, such as location, date, names of the home and visiting team and names of the officials.

A4.22 - SCOREKEEPER'S DUTIES DURING THE GAME

a) The Scorekeeper shall record on the Official Game Sheet:

1. The goals scored.
2. The number of the scorers and players to whom assists have been awarded
3. The players of both teams who are on the ice when a goal is scored.
4. All penalties imposed by the officials with the numbers of the penalized players, the infraction, the time at which it has been imposed, and the duration of each penalty.
5. Each Penalty Shot awarded with the name of the player taking the shot and the result of the shot.
6. The time of entry into the game of any substitute goalkeeper.
 - ▶ In top category IIHF Championships and the Olympic Winter Games, the Scorekeeper shall determine the players entitled to receive assists.
 - ▶ No request for changes in any awarded of points shall be considered unless they are made by the Captain before the conclusion of actual play in the game or before the Referee has signed the Official Sheet.

b) The Scorekeeper shall be responsible for:

1. Correct posting of the penalties and goals scored on the scoreboard,
2. Ensuring that the time served by all penalized players is correct,
3. Promptly calling to the attention of the referee any discrepancy between the time recorded on the clock and the official correct time,
4. Making any adjustments as ordered by the referee,
5. Advising the referee when the same player has received his second Misconduct penalty in the same game.
6. Notify the referee if a player, not listed on the game sheet is participating in the game.



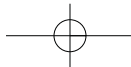

A4.23 - SCOREKEEPER'S DUTIES AFTER THE GAME

The Scorekeeper shall prepare the Official Game Sheet for signature by the Referee and forward it to the **Proper Authorities**.

A4.24 - TIMEKEEPER

- a) The Timekeeper shall record:
 1. Game countdown before the game (see Annex 2 - Game Countdown and Warm-up Procedures),
 2. Time of starting and finishing of each period and game
 3. 15 minute intermission between each period
 4. All actual playing time during the game
 5. Time of the start and finish of all penalties
 6. Start and finish of time-outs
- b) In case no automatic buzzer or siren is provided, he shall signal by a buzzer, siren or whistle the end of each period or overtime period.
- c) The Timekeeper shall give a preliminary warning by signal to the officials and both teams three minutes before the start of each period and two minutes before the start of each period.
- d) In the event of any dispute regarding time, the referee's decision shall be final.

A4.25 - ANNOUNCER

The Announcer shall announce by means of a public address system:

1. Awarding of goals and assists
 2. Penalties
 3. End of penalties
 4. When one minute remains in the first and second period
 5. When two minutes remain in the third period
- ▶ See Annex 3 for the wording of the official announcements.

A4.26 - PENALTY BENCH ATTENDANTS

- a) One Penalty Bench Attendant shall be appointed for each team penalty bench.
- b) The Penalty Bench Attendant shall be responsible for:
 1. Providing a penalized player, upon request, with the correct information as to the unexpired time of the penalty.
 2. Allowing the penalized player to return to the ice at the appropriate time upon the completion of the penalty.
 3. Notifying the Scorekeeper if a player leaves the penalty bench before the end of the penalty.



ANNEX 5 - ILLUSTRATION OF GOAL FRAME

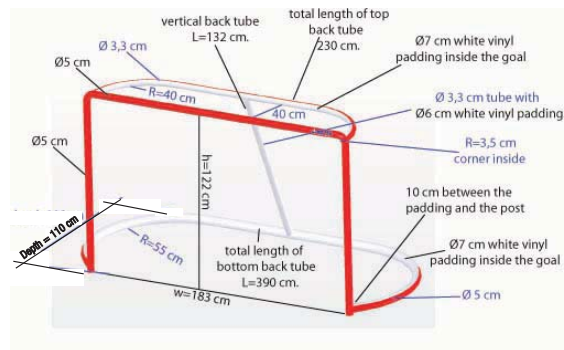

REFEREE SIGNALS

ATTACKING A PLAYER IN THE GOAL CREASE - RULE 595

Semi-circular motion by one arm at chest height made parallel to the ice surface, simulating the goal crease, and then extending the other arm horizontally with the hand pointing in the direction of the neutral zone.



BOARDING - RULE 520

Striking the clenched fist of one hand into the open palm of the opposite hand in front of the chest.

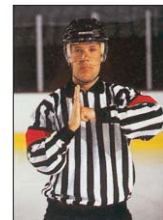



BUTT-ENDING - RULE 521

A cross motion of the forearms, one moving under the other. Upper hand is open and the lower hand a clenched fist.

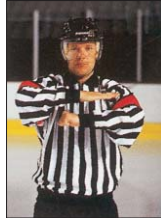

CLIPPING - RULE 524

Striking leg with either hand below the knee from behind, keeping both skates on the ice.

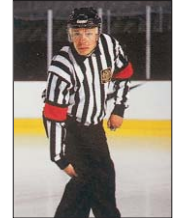

PLAYER CHANGE SIGNAL - RULE 412

The Referee allows a five second period to the visiting team to make a player(s) change. After the five seconds, the Referee shall raise his arm, which indicates that the visiting team may no longer change any player and the home team has five seconds to change players.

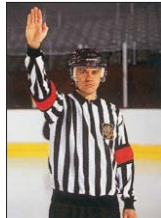

CROSS-CHECKING - RULE 525

A forward and backward motion of the arms with both fists clenched, extending from the chest for a distance of about a half a meter.

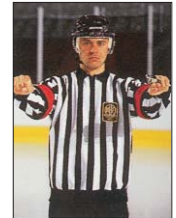

CHARGING - RULE 522

Rotating clenched fists around one another in front of the chest.

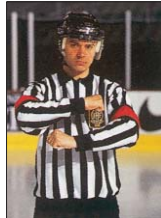

DELAYED CALLING OF PENALTY - RULE 514

Extended the non-whistle arm fully above the head. It is acceptable to point at the player once and then extend the arm above the head.

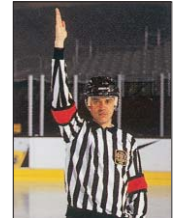

CHECKING FROM BEHIND - RULE 523

A forward motion of both arms, with the palms of the hands open and facing away from the body, fully extended from the chest at shoulder level.



DELAYING THE GAME - RULE 554

Placing the non-whistle hand, open palm, across the chest and extended from the shoulder out from the body.

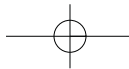



ELBOWING - RULE 526

Tapping either elbow with the opposite hand.

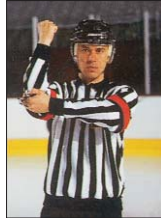

HOLDING - RULE 531

Grasping either wrist with the other hand in front of the chest.

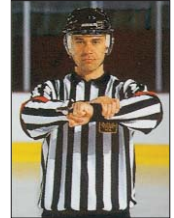

PUCK IN THE NET - RULE 470

An extension of the arm pointing at the goal to indicate the puck has entered the net



HOLDING THE STICK - RULE 532

Two stage signal involving the holding signal followed by an indication you are holding onto a stick with two hands in a normal manner.

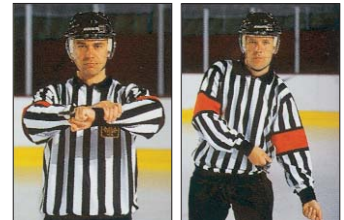

HAND PASS - RULE 490

Use open palm of hand in a pushing motion.

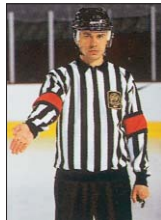

HOOKING - RULE 533

A tugging motion with both arms as if pulling something from in front toward the stomach.

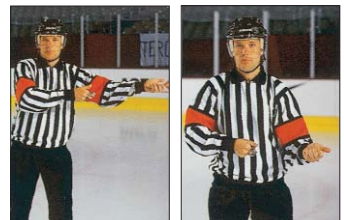

HIGH STICKING - RULE 530

Holding both fists clenched, one immediately above the other at the height of the forehead.

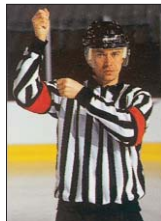

INTERFERENCE - RULE 534

Crossed arms with closed fists stationary in front of the chest.

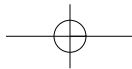
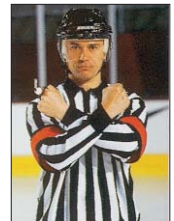



KNEEING - RULE 536

Tapping either knee with the palm of the hand, while keeping both skates on the ice.

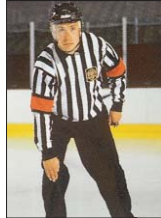

ROUGHING - RULE 528

Fist clenched and arm extended out to the side of the body.



MATCH PENALTY - RULE 507

Patting the palm of the hand on top of the head.

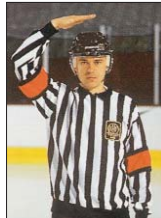

SLASHING - RULE 537

A chopping motion with the edge of one hand across the opposite forearm.

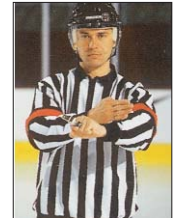

MISCONDUCT PENALTY AND GAME MISCONDUCT PENALTY - RULES 504, 505

Both hands on the hips.

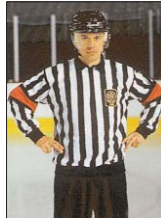

SPEARING - RULE 538

Jabbing motion with both hands thrusting out immediately in front of the body and then hands lowered to the side of the body.

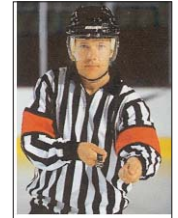

PENALTY SHOT - RULE 508

Arms crossed above the head. Give the signal upon stoppage of play.

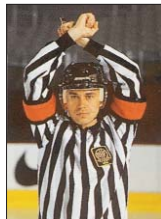

TIME OUT - RULE 422

Using both hands to form a "T" in front of the chest.

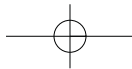
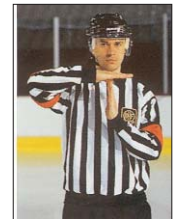

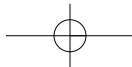

TOO MANY PLAYERS ON THE ICE - RULE 573

Indicate with six fingers (one hand open) in front of the chest.



TRIPPING - RULE 539

Striking leg with a moving follow through motion with either hand below the knee keeping both skates on the ice.

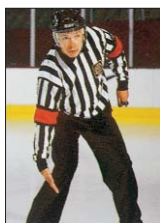

WASH OUT

A sweeping sideways motion of both arms across the front of the body at shoulder level with palms down;

- ▶ by the Referee to signal 'no goal', 'no handpass' 'no highsticking the puck'.
- ▶ by the Linesman to signal 'no icing' and, in certain situations, 'no offside'.

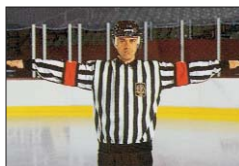

CHECKING TO THE HEAD AND NECK AREA - RULE 540

The side movement of the open palm of the hand towards the side of the head.

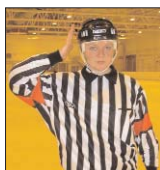

WOMEN BODY CHECKING - RULE 541

The palm of the non-whistle hand is brought across the body and placed on the opposite shoulder.



LINESMAN'S SIGNALS

DELAYED OFFSIDE - RULE 451

Non-whistle arm fully extended above the head. To cancel out a delayed offside, the Linesman shall lower the arm to the side.



ICING THE PUCK - RULE 460

The back Linesman (or Referee in the two-man system) signals a possible icing, by fully extending either arm over his head. The arm shall remain raised until the front Linesman or Referee, either blows the whistle to indicate an icing, or until the icing is washed out. Once the icing has been completed, the back Linesman or Referee shall first cross his arms in front of the chest and then shall point to the appropriate face-off spot and skate to it.



OFFSIDE CALL - RULE 450

The official shall first blow the whistle and then extend the arm horizontally pointing along the blue line with the non-whistle hand.

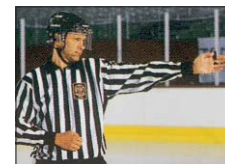

INDEX

Item	Rule N°
Abuse of Officials	550,551
Actual Time	420,500
Adjustment of Equipment	554d
Advertising	Annex 1
Altercation	564,593
Alternate Captain	201,572
Announcements	Annex 3
Announcer	300,324, Annex 4.25
Assist	472
Attacking Zone	112,490,569
Authorities (Proper)	340
Bench (Penalty)	141,562,563,564
Bench (Players)	140,562,564,592
Bench Minor Penalty	502
Blade of the Stick	222,232,234
Blocking Glove	233a
Blood	418,571
Blue Line	112,450,451,533,539,570
Boarding	503,520
Boards	102
Body Checking (Women)	601
Breakaway	533,539,570
Broken Stick	556
Butt-ending	521
Calling of Penalties	514
Captain	201,566,567,572
Catching Glove	233b
Center Line	113,460,591
Change of Goalkeeper	415
Change of Players	410 to 413,554f,575
Charging	522
Checking from Behind	503,523
Chin Strap	223
Circle	114,115,117,440
Clipping	524
Clock	152
Coach	200,201,500,550a,567
Coincidental Penalties	512
Completion of Play	514
Composition of Teams	200
Control of the Puck	533,539
Count-down	152,Annex 2

Crease (Goal)	119,460,470,534,557,558
Crease (Referee)	118,550
Cross-checking	503,525
Curve (of a Stick)	222,232
Defending Zone	112,440,490,533,569,570
Delayed Offside	451
Delayed Penalty	513
Delaying the Game	554
Discipline (Supplementary)	510
Displacing the Goal	471,554b
Diving	550a
Doors	104
Dressing Rooms (Players)	160
Dressing Rooms (Referees)	161
Elbowing	503,526
Equipment (Goalkeeper)	230
Equipment (Illegal or dangerous)	555
Equipment (Players)	220
Equipment (Measurement)	260,555
Equipment (Officials)	311
Excessive Roughness	527
Face-off Spots	114 to 117,440
Face-offs	313,440,442,554g
Falling on the Puck	557,558
Fisticuffs	528
Forfeit	200,566,567
Full Face Mask	234, 528h
Full Strength	512, Annex 3
Game Misconduct Penalty	505,
Glass (Protective)	105
Glove (Goalkeeper)	233
Glove (Player)	225,528,555
Goal Frame (Net)	130
Goal (Score)	470,471,472
Goal Crease	119,460,470,534,557,558
Goal Judge	142,321
Goal Line	111,460,558
Goalkeeper Equipment	230
Goalkeeper Penalty	509,511,554c,558,560,569,590 to 594
Hair	240, 528h
Hand	490,559,560
Handling the Puck with the Hands	490,559,560
Head-butting	529
Head (Checking to the Head)	540
Helmet	223,234

High Sticking the Puck	492
High Sticking (a Player)	530
Holding	531
Holding the Stick	532
Home Team	240,412
Hooking	533
Icing the Puck	440,460
Incapacitated Referee/Linesman	Annex 4.1, 4.2
Infections (Prevention of)	418,471
Injured Player, Goalkeeper	416,417,554e
Intentional Offside	450
Interference	534
Intermission	420
Junior	227,650,651
Kicking a Player	535
Kick Plate	103,110 note
Kicking the Puck	491
Kneeing	503,536
Last Two Minutes of the Game	554b,573, Annex 3,A4.25
Leaving the Penalty Bench	562,563,563,
Leaving the Player's Bench	562,563,564,565
Leg Guards(Goalkeeper)	210,235
Lighting of the Rink	170
Lights (Red and Green)	153
Line (Blue)	112,450,451,533,539,570
Line (Center)	113,460,591
Line (Goal)	111,460,558
Line-up	402 note 3, Annex 2
Linesman	300,311,313,A4.7
Major Penalty	503
Manager	200,201,401,500,567
Masks (Full Face)	234
Match Penalty	507
Measurement of Equipment	260,555
Minor Penalty	501
Misconduct Penalty	504
Mouth Guard	227
Music	172,Annex 2
Net (End Zone Nets)	106
Net (Goal Net)	130,481,594
Neutral Zone	112,116,140,440,490,569
Officials (On Ice)	310,Annex 4.1 to Annex 4.11
Officials (Off-ice)	320,Annex 4.20 to 4.26
Officials (Team)	551,553,565
Offside	442,450,451

One Minute Left in 1st and 2nd Period	Annex 2,Annex 3
Overtime	421,554b,573
Penalties	500
Penalty Bench	141,562,563,564
Penalty Bench Attendant	300,325,A4.26,562
Penalty Shot	508,509
Penalty Shot (Game Winning)	431
Period	420,421
Play-off Game	421
Players Bench	140,562,564,592
Players on the Ice	400
Point (Goal-Assist)	472
Possession of the Puck	533,534
Puck	250,330b,450,460,480, 484,490,491,492
Puck in Motion	554a
Puck out of Bounds, Unplayable	480,481,482,554c
Puck Outside of the Goal Net	481,594
Puck Striking an Official	470,484
Referee	300,311,312,Annex 4
Referee Crease	118,550
Referee/Linesmen System	A 4.3 to A 4.7
Referee/Linesman Signals	Annex 5
Refusing to Start Play	566,567
Outcome (Result) of a Game	430
Rink	100,101
Rink (Open air)	110,420
Rolling an Opponent	520
Roughing	528
Roughness	527
Scoreboard	152
Scorekeeper	143,300,322, Annex 4 .21 to A4.23
Shooting the Puck Outside the Playing Area	554c
Short Handed	460,502,514,554a
Siren	151
Skate	221,231,450,451
Slashing	503,537
Smoking Prohibition	171
Spearing	503,538
Spectators (Interference by)	493
Spectators (Interference with)	561
Spitting	550,551
Spots (Face-off)	114 to 117,440
Start of Game and Periods	402,566,567
Stick (Broken Stick)	556
Stick (Goalkeeper)	232

Omissions, Clarifications & Updates for the 2010 IIHF Rule Book

Page 4, Section 4 - Playing Rules

Omissions:

- 410 Change of players and Goalkeepers - **should be deleted**
- 411 Change of Players **and Goalkeepers** from the Players' Bench during Play
- 419** Ice Cleaning

Page 25, Elbow Pads – Rule 228

Page 35, Rule 411 – Change of Players and Goalkeepers From the Player's Bench During Play

Update:

- c) If, during a substitution, the goalkeeper departing the ice plays the puck or makes any physical contact with an opponent while the entering player is actually on the ice, the Referee shall assess a **Bench** Minor Penalty for Too Many Players on the ice (Rule 573)

Page 36, Rule 412 – Change of Players Procedure during Stoppage of Play

Update:

"This penalty shall be announced as a **"Bench Minor Penalty for the Delay of Game - Violation of change of players after icing the puck"**

Page 39, Rule 413 – Change of Players from the Penalty Bench

Clarification:

- "Bench Minor penalty" - **Delete reference to Rule 562**

Page 39, Rule 419 – Ice Cleaning

Clarification:

- b) "If a goalkeeper...."

Page 51, Rule 482 – Puck Out of Sight

Clarification:

Delete the word **"point"** in the text

Page 62, Rule 512 – Coincidental Penalties

Clarification:

The word **"NEW"** relates to the note listed above

Page 73, Rule 528 - Fisticuffs or Roughing

Clarification:

- h) Should be:
- Minor penalty (2')
 - Or
 - Double **Minor** penalty (2'+2')
 - Or
 - Major penalty + Automatic Game Misconduct penalty (5'+GM)

Page 77, Rule 533 - Hooking

Clarification:

- d) If, when the opposing goalkeeper has been removed from the ice, and the player in control of the puck outside of his own defending zone **has** no opponent **to pass** between him and the opposing goal

Page 81, Rule 539 - Tripping

Clarification:

- d) If, when the opposing goalkeeper has been removed from the ice, and the player in control of the puck outside of his own defending zone **has** no opponent **to pass** between him and the opposing goal

Page 99, Rule 562 – Players Leaving the Penalty or Players’ Bench

Clarification:

- f) Any other player(s) who leave the penalty bench during an altercation shall be assessed a:
- Minor penalty + **Misconduct** penalty (2'+10')

This will be served at the expiration of his previous penalty

Page 104, Rule 575 – Infringement of Change of Players Procedure

Update:

“Penalties assessed under this rule shall be announced as **Bench Minor Penalty for the Delay of Game – Violation of Change of Players Procedure**”

Page 130, Index

Omission:

Sudden **Death** 421, **430**